



PRODUCT SPECIFICATIONS

For Customer: _____ : APPROVAL FOR SPECIFICATIONCustomer Model No. _____ : APPROVAL FOR SAMPLE

Module No.: PV05039D0150L

Date : 2016-01-20

Table of Contents

No.	Item	Page
1	Cover Sheet(Table of Contents)	
2	Revision Record	
3	General Specifications	
4	Outline Drawing	
5	Absolute Maximum Ratings	
6	Electrical Specifications and Instruction Code	
7	Optical Characteristics	
8	Reliability Test Items and Criteria	
9	Packing Reliability	
10	MTBF Report	

For Customer's Acceptance:

Approved By	Comment

PREPARED	CHECKED	VERIFIED BY QA DEPT	VERIFIED BY R&D DEPT



2. Revision Record

Date	Rev.No.	Page	Revision Items	Prepared
2016-01-20	V0		The first release	ZHP
2016-5-10	V1		Change the CLK	Jimmy



3. General Specifications

PV05039D0150L is a TFT-LCD module. It is composed of a TFT-LCD panel, driver IC, FPC, a back light unit. The 5.0" display area contains 640 x 480 pixels and can display up to 16.7M colors. This product accords with RoHS environmental criterion.

Item	Contents	Unit	Note
LCD Type	TFT	-	
Display color	16.7M		
Viewing Direction	12	O'Clock	
Gray scale inversion direction	6	O'Clock	
Operating temperature	-20~+70	°C	
Storage temperature	-30~+80	°C	
Module size	Refer to outline drawing	mm	
Active Area(W×H)	101.57X76.18	mm	
Number of Dots	640×480	dots	
Controller	-	-	
Power Supply Voltage	3.3	V	
Outline Dimensions	Refer to outline drawing	-	
Backlight	3X6-LEDs (white)	pcs	
Weight	---	g	
Interface	RGB888	-	



4. Outline Drawing

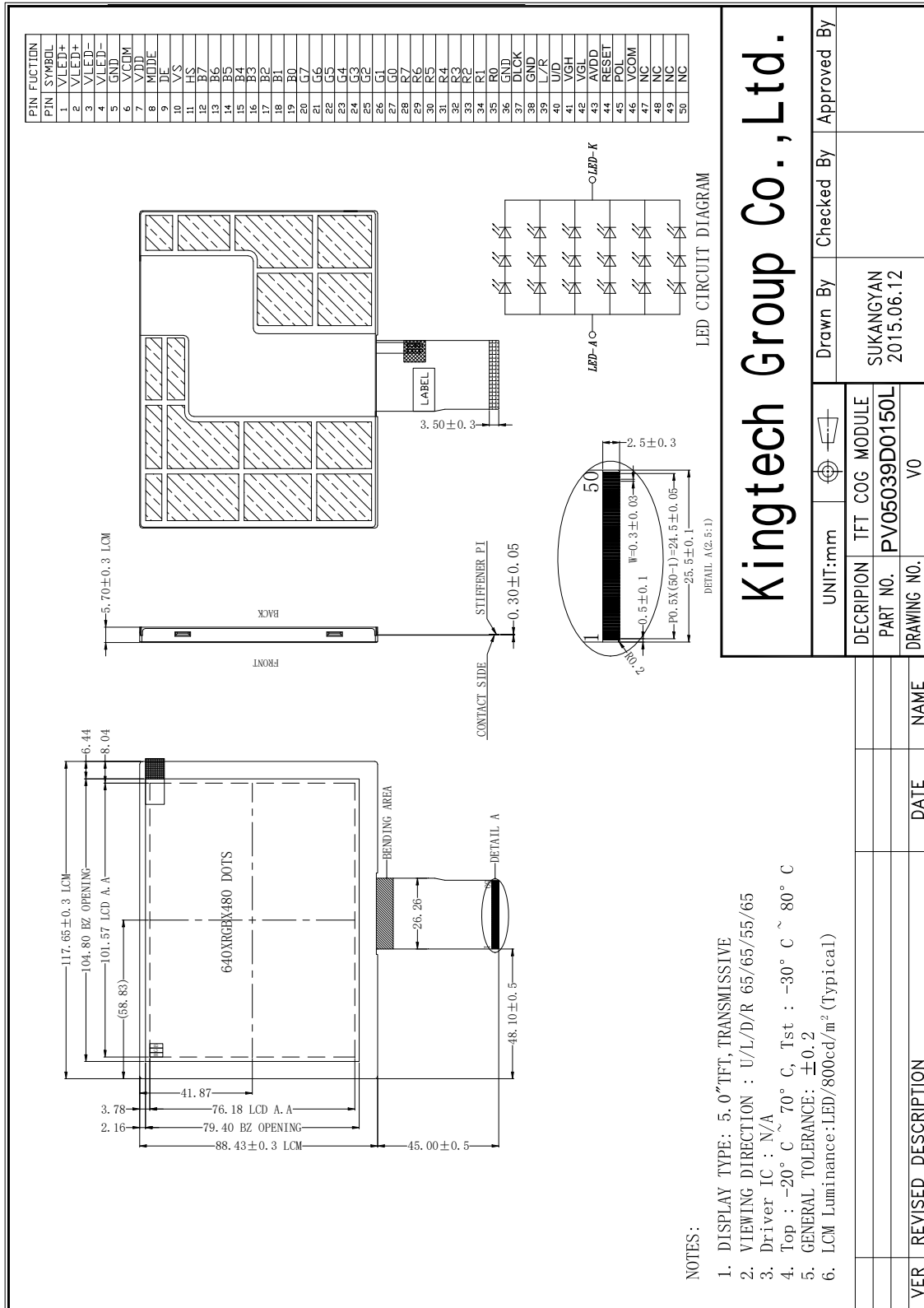



5. Absolute Maximum Ratings(Ta=25°C)

5.1 Electrical Absolute Maximum Ratings.(Vss=0V ,Ta=25°C)

Item	Symbol	Min.	Max.	Unit	Note
Power Supply Voltage	V _{DD}	-0.3	5.0	V	1, 2
	AV _{DD}	6.5	13.5	V	
	V _{GH}	-0.3	40.0	V	
	V _{GL}	-20	0.3	V	
	V _{GH} -V _{GL}	-	40.0	V	

Notes:

1. If the module is above these absolute maximum ratings. It may become permanently damaged.
Using the module within the following electrical characteristic conditions are also exceeded, the module will malfunction and cause poor reliability.
2. V_{CC} >V_{SS} must be maintained.

5.2 Typical operation conditions

Item	Symbol	Values			Unit	Remark
		Min.	Typ.	Max.		
Power voltage	VDD	3.0	3.3	3.6	V	
	AVDD	10.2	10.4	10.6	V	
	VGH	16.7	17.0	17.3	V	
	VGL	-7.3	-7.0	-6.7	V	
Input signal voltage	VCOM	3.2	3.5	3.8	V	
Input logic high voltage	VIH	0.7 VDD	-	VDD	V	
Input logic low voltage	VIL	0	-	0.3VDD	V	



5.3 Environmental Absolute Maximum Ratings.

Item	Storage		Operating		Note
	MIN.	MAX.	MIN.	MAX.	
Ambient Temperature	-30°C	80°C	-20°C	70°C	1,2
Humidity	-	-	-	-	3

1. The response time will become lower when operated at low temperature.
2. Background color changes slightly depending on ambient temperature.

The phenomenon is reversible.

3. $T_a \leq 40^\circ\text{C}$: 85%RH MAX.

$T_a > 40^\circ\text{C}$: Absolute humidity must be lower than the humidity of 85%RH at 40°C .



6. Electrical Specifications and Instruction Code

6.1 Electrical characteristics(V_{SS}=0V ,Ta=25°C)

Parameter	Symbol	Condition	Min	Typ	Max	Unit	Note	
Power supply	V _{CC}	Ta=25°C	3.0	3.0	3.3	V		
Input voltage	'H'	V _{IH}	V _{CC} =3.0V	0.7V _{CC}	-	V _{CC}	V	
	'L'	V _{IL}	V _{CC} =3.0V	0	-	0.3V _{CC}	V	
Current Consumption	I _{CC1}	Normal mode	-	25	45	mA	1	
	I _{CC2}	Sleep mode	-	0.05	0.1	mA	1	
Clock Frequency	f _{CLK}	-	30	37	50	MHz		

Note:

1: Tested in 1×1 chessboard pattern.



6.2 LED backlight specification(VSS=0V ,Ta=25°C)

Item	Symbol	Condition	Min	Typ	Max	Unit	Note
Supply voltage	Vf	If=20mA X6	-	9.9	-	V	
Uniformity	Δ Bp	If=20mA X6	75			%	
Luminance for LCD	Lv	If=20mA X6	-	800		Cd/m2	
Life time	Hours	If=20mA X6	50000				1

Note1:

LED power consumption is around 1.1W.

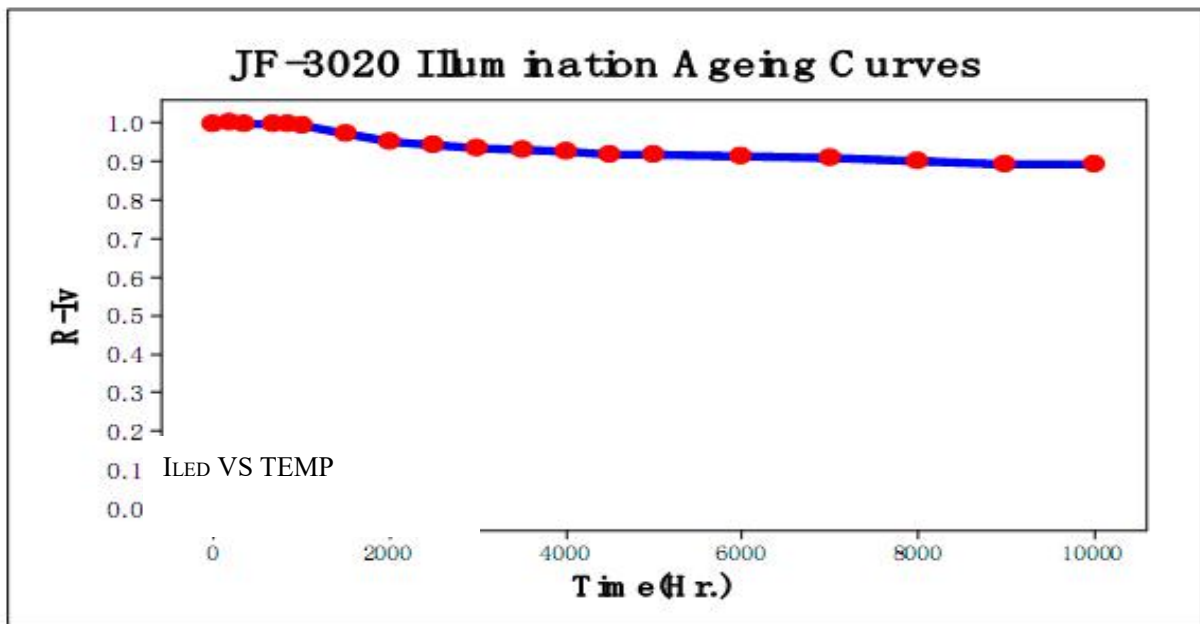

4. The analysis of regression and the prediction of aging

Therefore, the equation of regression is:

$$\ln R-Iv = -0.000013 t$$

For R-IV=50%, $\ln 0.5 = -0.69315$, $-0.69315 = -0.000013t$

$t = 53319$ Hrs.

As far as the statistic above concerned, we can easily arrive at the conclusion: it will take approximately 53319 Hrs for the illumination of our product to attenuate to 50%.



6.3 Interface signals

Pin No.	Symbol	I/O	Function
1-2	VLED+	P	LED back light(Anode)
3-4	VLED-	P	LED back light(Cathode)
5	GND	P	Ground.
6	VCOM	I	VCOM input
7	DVDD	P	Power for Digital Circuit
8	MODE	I	DE or HV mode control
9	DE	I	Data Enable
10	VS	I	Vsync signal input
11	HS	I	Hsync signal input
12-19	B7-B0	I	Blue data input
20-27	G7-G0	I	Normal display and Standby mode select pin
28-35	R7-R0	I	Frame sync signal
36	GND	P	Power ground
37	DCLK	I	Sample clock
38	GND	P	Power ground
39	L/R	I	Select left to right scanning direction
40	U/D	I	Select up or down scanning direction
41	VGH	I	Positive power for scan driver
42	VGL	I	Negative power for scan driver
43	AVDD	P	Power for Analog Circuit
44	RESET	I	Reset
45	NC	-	No Connector
46	VCOM	I	VCOM input
47-50	NC		No connection.

NOTE:

Setting of scan control input		Scanning direction
U/D	L/R	
DV _{DD}	DV _{DD}	Up to down, left to right
GND	DV _{DD}	Down to up, left to right
DV _{DD}	GND	Up to down, right to left
GND	GND	Down to up, right to left



7. Optical Characteristics

Item	Symbol	Condition	Min.	Typ.	Max.	Unit	Note
Brightness	Bp	$\theta=0^\circ$	-	800	-	Cd/m ²	1
Uniformity	ΔBp	$\Phi=0^\circ$	75	-	-	%	1,2
Viewing Angle	3:00	$Cr \geq 10$	-	65	-	Deg	3
	6:00		-	55	-		
	9:00		-	65	-		
	12:00		-	65	-		
Contrast Ratio	Cr	$\theta=0^\circ$ $\Phi=0^\circ$	400	500	-	-	4
Response Time	T _r		-	10	-	ms	5
	T _f		-	10	-	ms	
Color of CIE Coordinate	W	x	-	0.28	-	-	1,6
		y	-	0.33	-	-	
	R	x	-	0.51	-	-	
		y	-	0.34	-	-	
	G	x	-	0.31	-	-	
		y	-	0.56	-	-	
	B	x	-	0.15	-	-	
		y	-	0.14	-	-	
NTSC Ratio	S	$\theta=0^\circ$ $\Phi=0^\circ$	50	60	-	%	

Note: The parameter is slightly changed by temperature, driving voltage and material

Note 1: The data are measured after LEDs are turned on for 5 minutes. LCM displays full white.

The brightness is the average value of 9 measured spots. Measurement equipment PR-705 (Φ8mm)

Measuring condition:

- Measuring surroundings: Dark room.
- Measuring temperature: Ta=25°C.
- Adjust operating voltage to get optimum contrast at the center of the display.

Measured value at the center point of LCD panel after more than 5 minutes while backlight turning on.

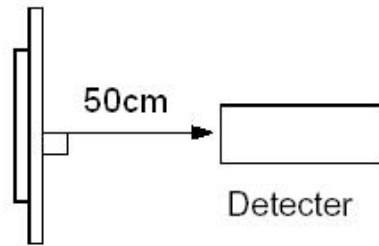

Note 2: The luminance uniformity is calculated by using following formula.

$$\Delta Bp = Bp (\text{Min.}) / Bp (\text{Max.}) \times 100 (\%)$$

Bp (Max.) = Maximum brightness in 9 measured spots

Bp (Min.) = Minimum brightness in 9 measured spots.

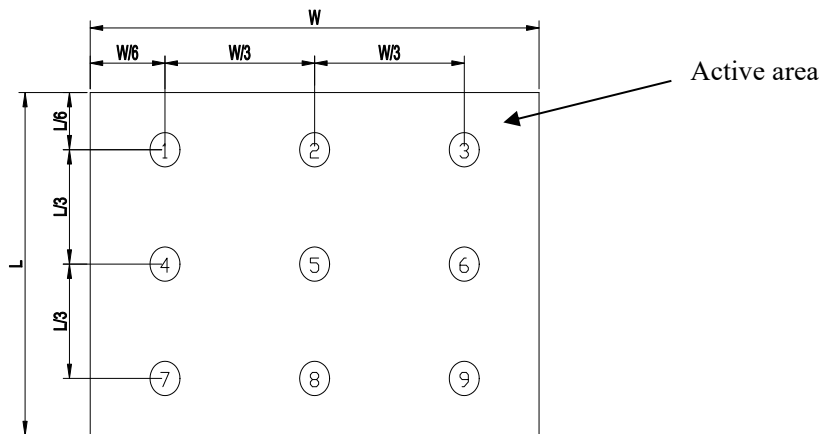

Note 3: The definition of viewing angle:

Refer to the graph below marked by θ and ϕ

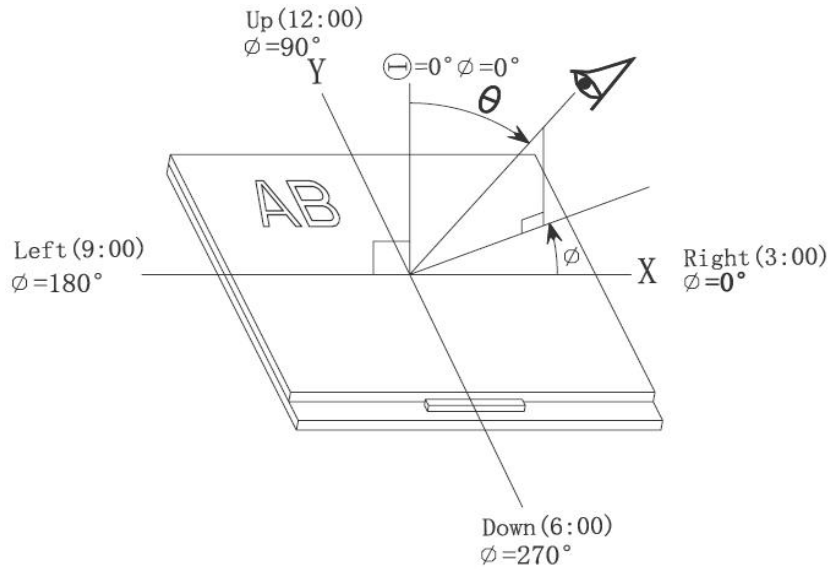

Note 4: Definition of contrast ratio.(Test LCD using DMS501)

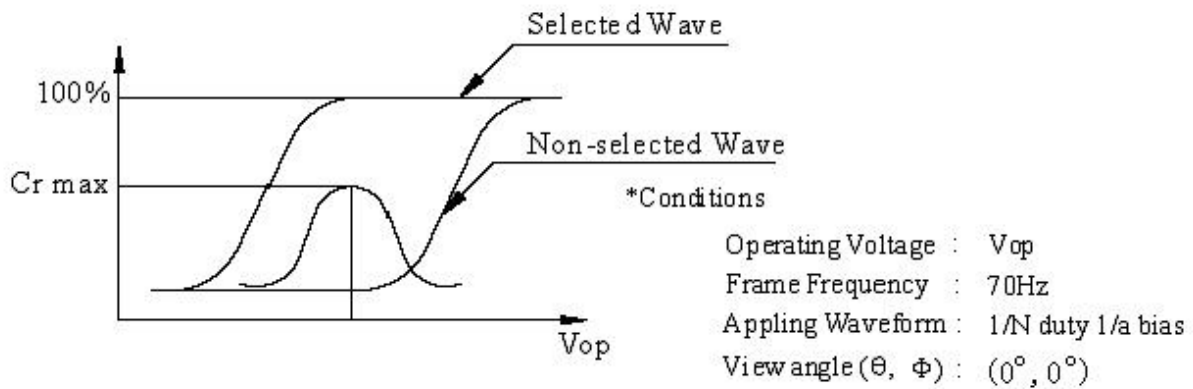

$$\text{Contrast ratio}(Cr) = \frac{\text{Brightness of selected dots}}{\text{Brightness of non-selected dots}}$$

Note 5: Definition of Response time. (Test LCD using DMS501):

The output signals of photo detector are measured when the input signals are changed from “black” to “white”(falling time) and from “white” to “black”(rising time), respectively. The response time is defined as the time interval between the 10% and 90% of amplitudes. Refer to figure as below.

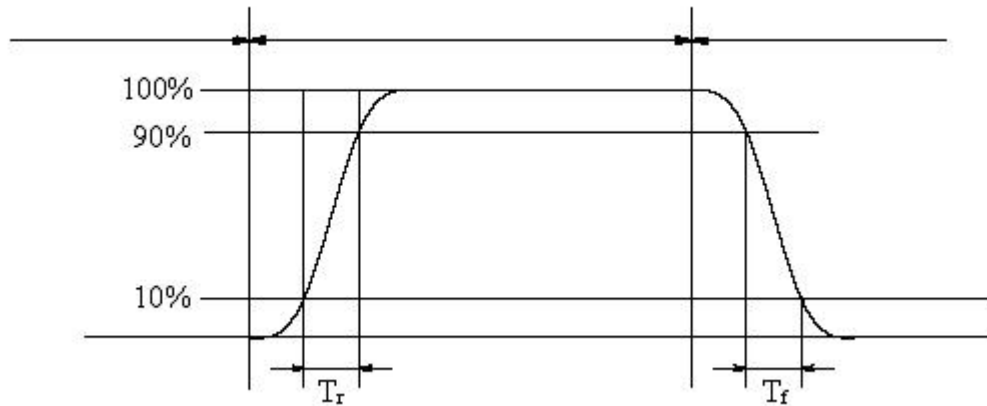

The definition of response time

Note 6: Definition of Color of CIE Coordinate and NTSC Ratio.

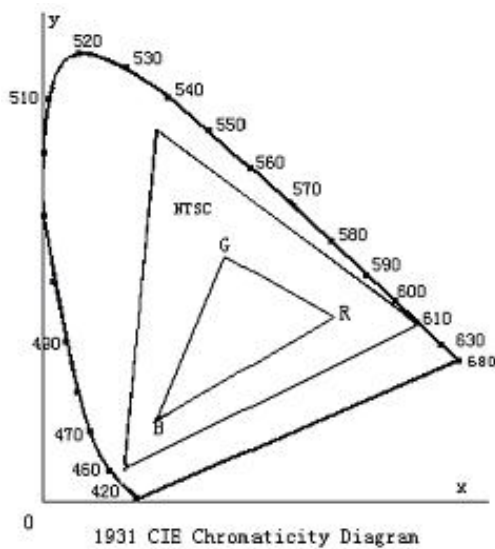

Color gamut:

$$S = \frac{\text{area of RGB triangle}}{\text{area of NTSC triangle}} \times 100\%$$

Note 7: Definition of cross talk.

$$\text{Cross talk ratio}(\%) = \frac{|\text{pattern A Brightness} - \text{pattern B Brightness}|}{\text{pattern A Brightness}} \times 100$$

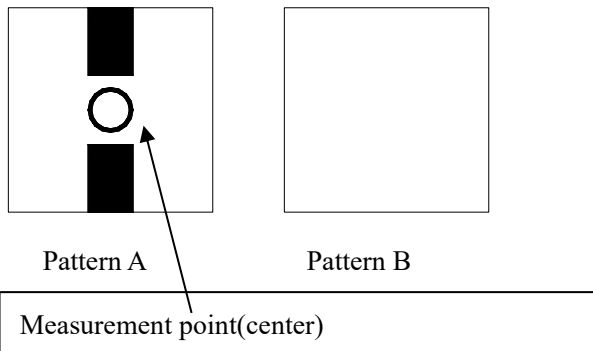

Electric volume value = 3F +/- 3Hex



8. Reliability Test Items and Criteria

No	Test Item	Test condition	Criterion
1	High Temperature Storage	80°C±2°C 240H Restore 2H at 25°C Power off	1. After testing, cosmetic and electrical defects should not happen. 2. Total current consumption should not be more than twice of initial value.
2	Low Temperature Storage	-30°C±2°C 240H Restore 2H at 25°C Power off	
3	High Temperature Operation	70°C±2°C 240H Restore 2H at 25°C Power on	
4	Low Temperature Operation	-20°C±2°C 240H Restore 4H at 25°C Power on	
5	High Temperature/Humidity Operation	60°C±2°C 90%RH 240H Power on	
6	Temperature Cycle	-30°C ←————→ 80°C 30min 5min 30min after 5 cycle, Restore 2H at 25°C Power off	
7	Vibration Test	10Hz~150Hz, 100m/s ² , 120min	Not allowed cosmetic and electrical defects.
8	Shock Test	Half- sine wave, 300m/s ² , 11ms	

Note: Operation: Supply 2.8V for logic system.

The inspection terms after reliability test, as below

ITEM	Inspection
Contrast	CR>50%
IDD	IDD<200%



Brightness	Brightness>60%
Color Tone	Color Tone+/-0,05

9. Precautions for Use of LCD Modules

9.1 Handling Precautions

9.1.1 The display panel is made of glass. Do not subject it to a mechanical shock by dropping it from a high place, etc.

9.1.2 If the display panel is damaged and the liquid crystal substance inside it leaks out, be sure not to get any in your mouth, if the substance comes into contact with your skin or clothes, promptly wash it off using soap and water.

9.1.3 Do not apply excessive force to the display surface or the adjoining areas since this may cause the color tone to vary.

9.1.4 The polarizer covering the display surface of the LCD module is soft and easily scratched. Handle this polarizer carefully.

9.1.5 If the display surface is contaminated, breathe on the surface and gently wipe it with a soft dry cloth. If still not completely clear, moisten cloth with one of the following solvents:

- Isopropyl alcohol
- Ethyl alcohol

Solvents other than those mentioned above may damage the polarizer.

Especially, do not use the following:

- Water
- Ketone
- Aromatic solvents

9.1.6 Do not attempt to disassemble the LCD Module.

9.1.7 If the logic circuit power is off, do not apply the input signals.



9.1.8 To prevent destruction of the elements by static electricity, be careful to maintain an optimum work environment.

- a. Be sure to ground the body when handling the LCD Modules.
- b. Tools required for assembly, such as soldering irons, must be properly ground.
- c. To reduce the amount of static electricity generated, do not conduct assembly and other work under dry conditions.
- d. The LCD Module is coated with a film to protect the display surface. Be care when peeling off this protective film since static electricity may be generated.

9.2 Storage precautions

9.2.1 When storing the LCD modules, avoid exposure to direct sunlight or to the light of fluorescent lamps.

9.2.2 The LCD modules should be stored under the storage temperature range. If the LCD modules will be stored for a long time, the recommend condition is:

Temperature : $0^{\circ}\text{C} \sim 40^{\circ}\text{C}$

Relatively humidity: $\leq 80\%$

9.2.3 The LCD modules should be stored in the room without acid, alkali and harmful gas.

9.3 The LCD modules should be no falling and violent shocking during transportation, and also should avoid excessive press, water, damp and sunshine.



10 MTBF Report

MTBF Calculate

10pcs samples are working at 60°C, 90%RH, worded 240H.
After working,sample is ok.

MTBF @ 25°C, 60%RH	MTBF=T*Af/GEM Factor c_L	41204	h
T _s =	Test temperature	60	°C
RH _s =	Test humidity	90%	-
n=	sample size	10	pcs
r=	No. of failure	0	pcs
t=	Test time	240	h
T _u =	Actual temperature	25	°C
RH _u =	Actual humidity	60%	-
E _a =	activation energy	0.6	eV/K
K=	Boltzman's constant	0.000086	eV/K
A _f =	Accelerate Factor $AF=(RH_s/RH_u)^3 \exp\{(E_a/k)*[(1/T_u)-(1/T_s)]\}$	39.5	-
T=	Total time=n*t	2400	h
C=	Confidence Level	0.9	-
GEM Factor c _L	$0.5*CHIINV(1-C, 2r+2)$	2.30	-

Note: The mode is selected by Hallberg-peck.