



**SPECIFICATION
FOR
LCD Module
PV05512T0239M-CO**

MODULE:	PV05512T0239M-CO
CUSTOMER:	

KINGTECH	INITIAL	DATE
PREPARED BY	杨荣武	20230803
CHECKED BY	陈志文	20230803
APPROVED BY	罗教平	20230803

CUSTOMER	INITIAL	DATE
APPROVED BY		



REVISION STATUS

Version	Revise Date	Page	Content	Modified by
V1.0	20230803	-	First Issued.	YANG
V1.1	2023.9.26	5	更新总图	YANG
V1.2	2023.10.10	5	更新总图	YANG



TABLE OF CONTENTS

- 1.General Description
2. Mechanical Characteristics
3. Pin Description
4. Electrical Characteristics
5. Optical Characteristics
6. Quality Specifications
7. Reliability
8. Handling Precaution
9. Package Drawing
10. 关键材料
- 11.测试报告
- 12.实验报告



10. General Description

* DESCRIPTION

PV05512T0239M-CO is a color active matrix TFT (Thin Film Transistor) LCD (liquid crystal display) that uses amorphous silicon TFT as a switching device. This model is composed of a Transmissive type TFT-LCD Panel, driver circuit, back-light unit. The resolution of a 5.46" TFT-LCD contains 1080 x 1920 pixels, and can display up to 16.7M colors.

* Features

- Low Input Voltage: IOVCC: 1.7~1.9V
- Display Colors of TFT LCD: 16.7M colors
- Interface: MIPI-4 Lanes
- Internal Power Supply Circuit.

General Information Items	Specification	Unit	Note
	Main Panel		
Display area(AA)	68.04(H) *120.96(V)	mm	-
Driver element	a-Si TFT active matrix	-	-
Display colors	16.7M	colors	-
Number of pixels	1080(RGB) *1920	dots	-
Pixel arrangement	RGB vertical stripe	-	-
Pixel pitch	0.063 (H) *0.063 (V)	mm	-
Viewing angle	All	o'clock	-
Drive IC	HX8399-C10	-	-
Touch IC	GT1151Q/GT1151QM	-	-
Display mode	Normally black	-	-
Operating temperature	-20~+70	°C	-
Storage temperature	-30~+80	°C	-

Mechanical Information

Item		Min.	Typ.	Max.	Unit	Note
Module size	Horizontal(H)	-	77.24	-	mm	±0.05
	Vertical(V)	-	139.90	-	mm	±0.05
	Depth(D)	-	2.71	-	mm	±0.2
Weight		-	TBD	-	g	-



2. MECHANICAL SPECIFICATION

保存期限: 三年

版本号: A/1

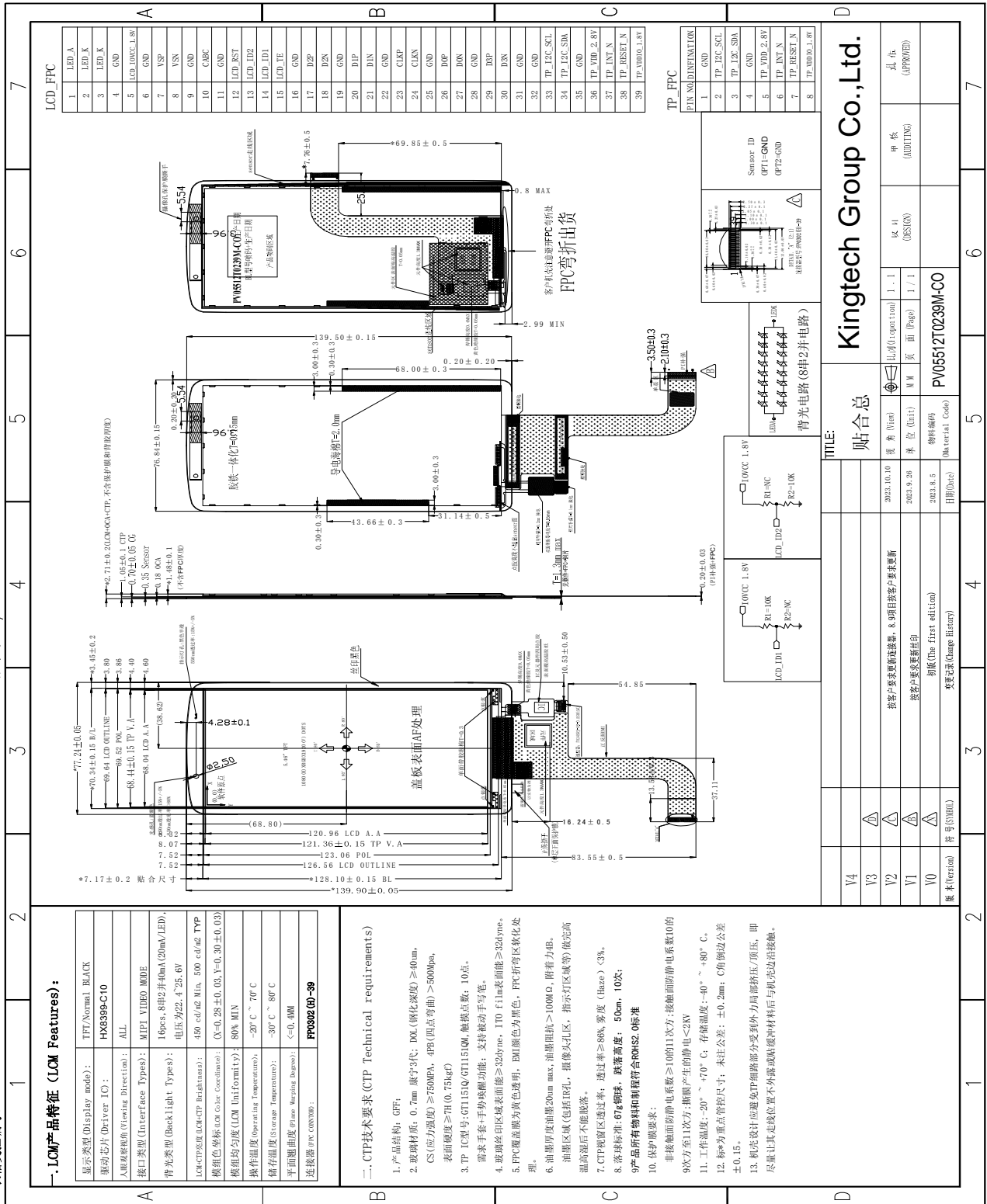

Kingtech Group Co., Ltd.

贴合总

V4	Δ	按客户要求更新连接器, 8.9脚直接客户更新	2023.10.10	版本号 (Ver)	1.1	页次 (Page)	1/1	物料编号 (Material Code)	PV05512T0239M-CO
V3	Δ	按客户要求更新连接器	2023.9.26	版本号 (Ver)	1.1	页次 (Page)	1/1	物料编号 (Material Code)	PV05512T0239M-CO
V2	Δ	按客户要求更新连接器	2023.8.5	版本号 (Ver)	1.1	页次 (Page)	1/1	物料编号 (Material Code)	PV05512T0239M-CO
V1	Δ	按客户要求更新连接器	2023.8.5	版本号 (Ver)	1.1	页次 (Page)	1/1	物料编号 (Material Code)	PV05512T0239M-CO
V0	Δ	初版 (The First edition)	2023.8.5	版本号 (Ver)	1.1	页次 (Page)	1/1	物料编号 (Material Code)	PV05512T0239M-CO

一. LCM产品特征 (LCM Features):

显示类型 (Display mode):	TFT/Normal BLACK
驱动芯片 (Driver IC):	HX8399-C10
入眼观察视角 (Viewing Direction):	ALL
接口类型 (Interface Types):	MIP1 VIBED MODE
背光类型 (Backlight Types):	16pcs, 8H2非0mm(20mA/LED), 电压为22.4~25.6V
背光亮度 (Backlight Brightness):	450 cd/m ² Min, 500 cd/m ² Typ
模色坐标 (Color Coordinate):	(X=0.28±0.03, Y=0.30±0.03)
模组均匀度 (LCM Uniformity):	80% Min
操作温度 (Operating Temperature):	-20°C ~ 70°C
储存温度 (Storage Temperature):	-30°C ~ 80°C
平面弯曲度 (Plane Warpage):	< 0.40mm
连接器 FPC CONSOLE:	FP0302 (0)-39

- 二. CTP技术要求 (CTP Technical requirements)**
1. 产品结构: GFF;
 2. 玻璃材质: 0.7mm 康宁代; DOL(钢化深度) ≥ 40um, CS(应力强度) ≥ 750MPa, 4PB(四点弯曲) > 5000Pa, 表面硬度 ≥ 7H (0.75kgf)
 3. TP IC型号: GT1151Q/GT1151QM, 触点点数: 10点, 需求手套+手持触控功能; 支持触控手写笔;
 4. 玻璃丝印区域表面能 ≥ 32dyne, ITO Film表面能 ≥ 32dyne;
 5. FPC覆层为灰色透明, 膜面颜色为黑色, FPC折弯区域硬化处理;
 6. 油墨厚度油膜20um max., 油墨阻抗 > 100Ω, 附着力B, 油墨区域 (包括IR孔, 摄像头孔区, 指示孔区域等) 做亮高油墨后不能脱落;
 7. CTP视窗区透过率: 透过率 ≥ 88%, 雾度 (haze) < 3%;
 8. 蒸球标准: 67g铜球, 跌落高度: 50cm, 10次;
 9. 产品所有物料制程符合RoHS2.0标准
 10. 保护膜要求:
 - 非接触面防静电系数 ≥ 100011次方; 接触面防静电系数10的9次方至11次方; 撕膜产生的静电 < 2KV
 - 11. 工作温度: -20° ~ +70° C, 存储温度: -40° ~ +80° C,
 - 12. 标*为重点管控尺寸; 未注公差: ±0.2mm; C作倒边公差 ±0.15.
 - 13. 封装设计/工艺避免IP向脚路部分受到外力高湿挤压/顶压, 即尽量让其走线位置不外露或经缓冲材料后与机壳边沿接触。



3. Pin Description

Pin NO.	Symbol	Level	Remark
1	LEDA	H	LED backlight+
2	LEDK	L	LED backlight-
3	LEDK	L	LED backlight-
4	GND	L	Power Ground
5	IOVCC(1.8V)	H	A supply voltage
6	GND	L	Power Ground
7	AVDD	H	Power supply 5V
8	AVEE	H	Power supply -5V
9	GND	L	Power Ground
10	PEM	H/L	PWM control the LED backlight
11	GND	L	Power Ground
12	RESET	H/L	Reset signal.
13	ID 2	L	Read ID
14	ID1	L	Read ID
15	TE	H/L	Output pin for scan line signal
16	GND	L	Power Ground
17	DSI_D2+	H/L	DSI_D2+ are differential data signal line
18	DSI_D2-	H/L	DSI_D2- are differential data signal line
19	GND	L	Power Ground
20	DSI_D1+	H/L	DSI_D1+ are differential data signal line
21	DSI_D1-	H/L	DSI_D1- are differential data signal line
22	GND	L	Power Ground
23	DSI_DCLK+	H/L	DSI_DCLK+ are differential data signal line
24	DSI_DCLK-	H/L	DSI_DCLK- are differential data signal line
25	GND	L	Power Ground
26	DSI_D0+	H/L	DSI_D0+ are differential data signal line
27	DSI_D0-	H/L	DSI_D0- are differential data signal line
28	GND	L	Power Ground
29	DSI_D3+	H/L	DSI_D3+ are differential data signal line
30	DSI_D3-	H/L	DSI_D3- are differential data signal line
31	GND	L	Power Ground
32	GND	L	Power Ground
33	TP-SCL	H/L	TP Serial clock input
34	TP-SDA	H/L	TP Serial data input pin
35	GND	L	Power Ground
36	TP-VDD(2.8V)	H	TP A supply voltage
37	TP-INT	H/L	TP Interrupt pin
38	TP-REST	H/L	TP Reset pin
39	TP-IOVD1(1.8V)	H	TP A supply voltage



4. ELECTRICAL CHARACTERISTICS

4.1 ABSOLUTE MAXIMUM RATINGS

Item	Symbol	Values		Unit	Remark
		Min	Max.		
Supply Voltage for Logic circuit	VDDIO	1.65	3.3	V	
Supply Voltage for analog circuit	Vcc	-	-	V	

4.2 DC ELECTRICAL CHARACTERISTICS

4.2.1 OPERATING CONDITIONS

Typical Operating Conditions (Ta=25°C)

Item	Symbol	Values			Unit	Remark
		Min	Typ	Max.		
Power Supply	Vcc	-	-	-	V	
Power Supply	VDDIO	1.65	1.8	3.3	V	
Normal mode Current consumption	Icc	-	-	20	mA	IOVCC=1.8V
Power Supply	AVDD	5.0	5.5	6.0	V	
Power Supply	AVEE	-6.0	-5.5	-5	V	

4.2.2 BACKLIGHT UNIT (GND=0V)

Item	Symbol	Values			Unit	Remark
		Min	Typ	Max.		
Forward supply Voltage	V _f	22.4	-	25.6	V	
Forward supply Current	I _f	-	40	-	mA	
LCM Luminance	L _V	450	480	-	cd/m ²	I _B =40mA
Uniformity	/	80			%	-



4.3 MIPI Interface Characteristics

DATA SHEET V01

4.4.1.2 Clock Lane Mode

Figure 4.13 shows the state diagram for Clock Lane Mode. The Clock Lane has three different power modes: Low Power Stop State, Ultra Low Power State (ULPS) and High Speed clock transmission.

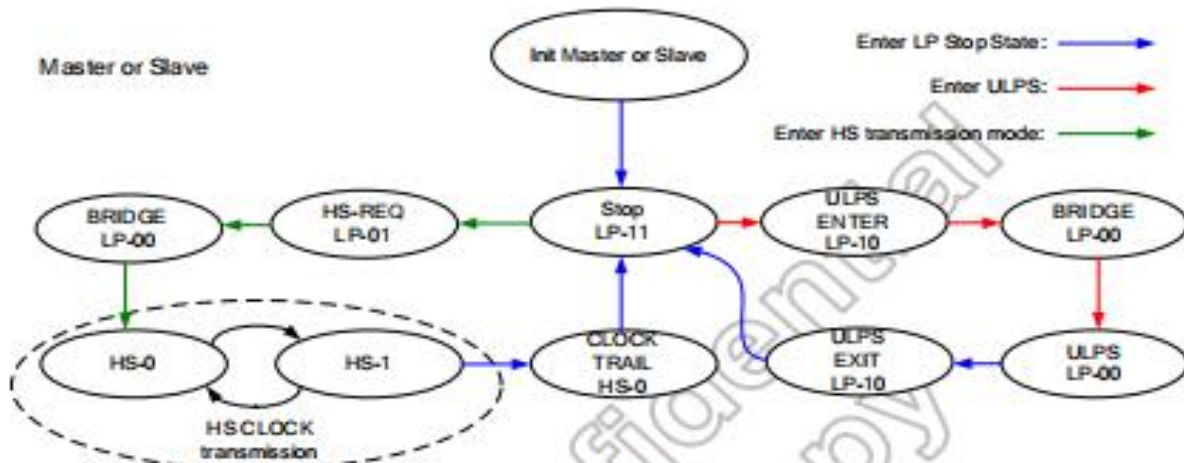
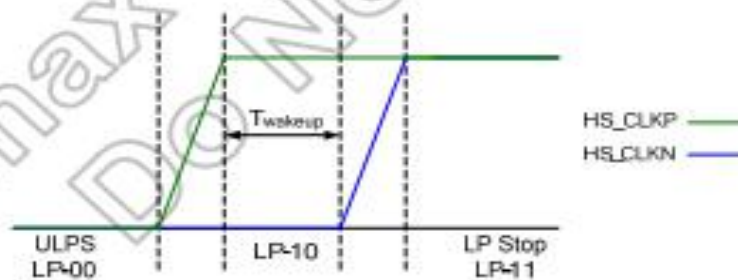

Figure 4.13: Clock Lane Mode State diagram

Clock Lane can be driven LP-11 to enter Low Power Stop State. There are three ways to enter Lower Power Stop State:

- A. After Initial state (HW reset, SW reset, Power on sequence).
- B. Leaving ULPS: ULPS LP-00 → LP-10 → Low Power Stop State LP-11.



- C. Leaving HS clock transmission mode: HS mode (HS-0 or HS-1) → HS-0 → Low Power Stop State LP-11.

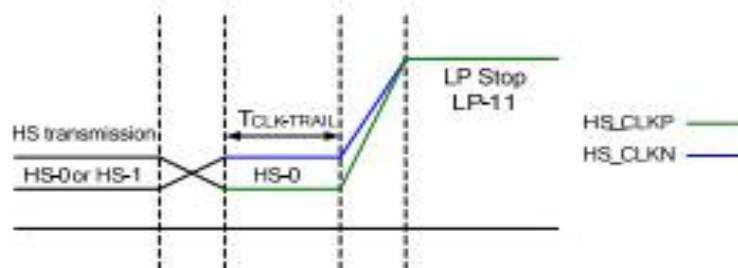



DATA SHEET V01

Clock lane can be driven LP-00 to enter ultra low power state from low power stop state. The flow is low power stop state LP-11 → LP-10 → ULPS LP-00.

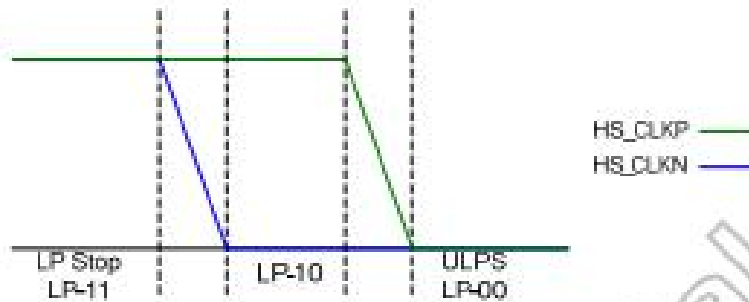

Clock lane can be high speed clock transmission state from low power stop state. The flow is low power stop state LP-11 → LP-01 → LP-00 → HS-0/1.

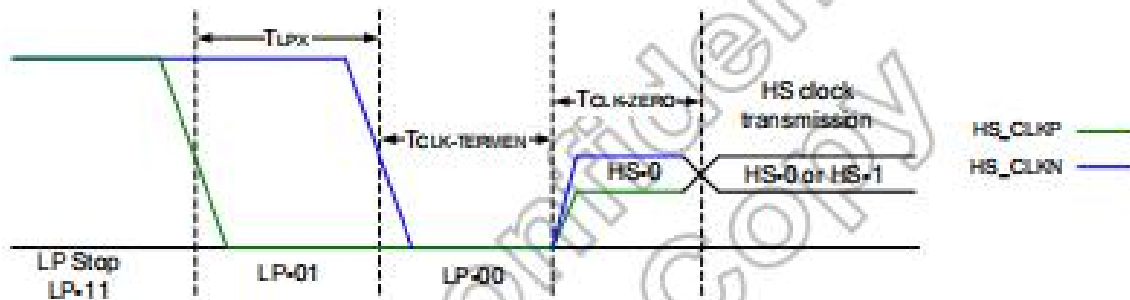



4.4.1.3.2 High speed data transmission

The display module can enter High Speed Data Transmission when Clock Lane in the High Speed Clock Mode. All Data Lane enter High Speed Data Transmission synchronously but may end at different time. Data Lane enters High Speed Data Transmission by the flow: LP-11 → LP-01 → LP-00 → SoT(HS-00011101). And exit High Speed Data Transmission flow: Toggles differential state immediately after last payload data bit and keeps that state for a time $T_{HS-TX,DL}$.

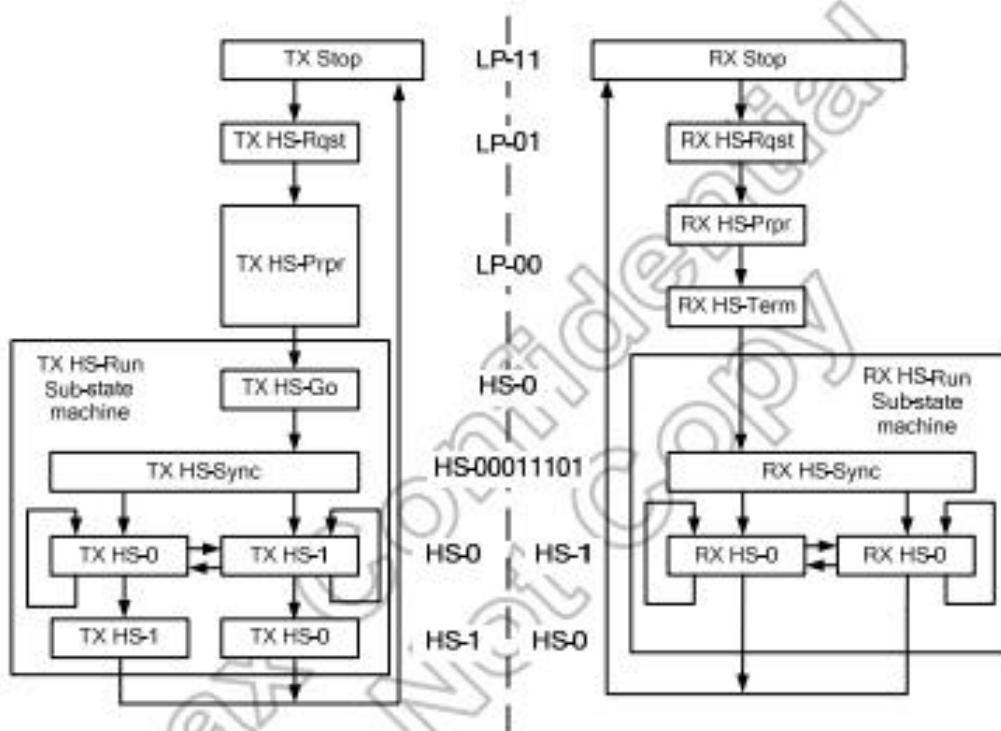

Figure 4.17: High Speed Data Transmission State Machine

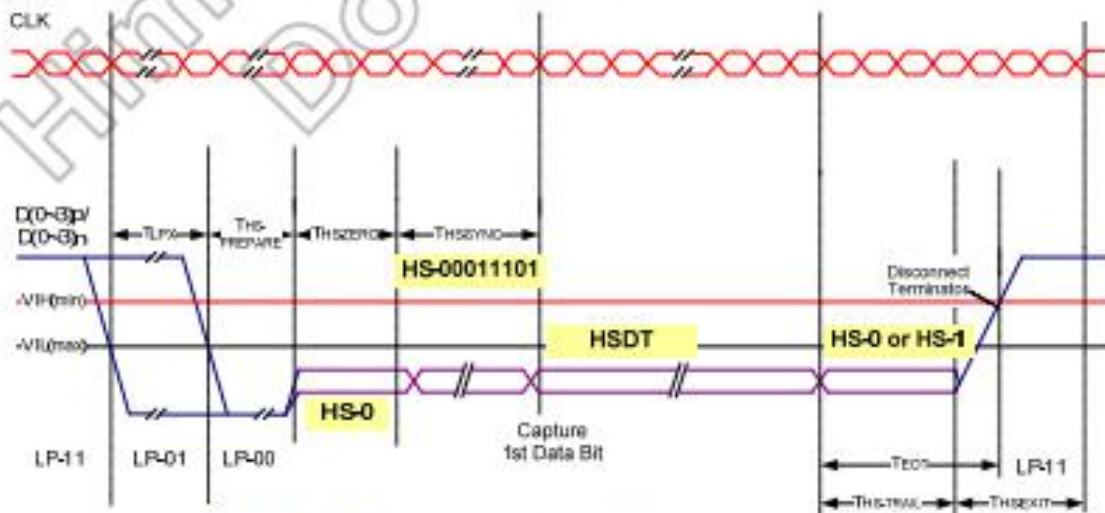

Figure 4.18: High Speed Data Transmission timing sequence



DATA SHEET V01

Parameter	Description	Spec.			Unit
		Min.	Typ.	Max.	
$T_{HS-PREPARE}$	Time that the transmitter drives the Data Lane LP-00 Line state immediately before the HS-0 Line state starting the HS transmission.	$40+4*UI$	-	$85+6*UI$	ns
$T_{HS-PREPARE} + T_{HS-ZERO}$	$T_{HS-PREPARE}$ + time that the transmitter drives the HS-0 state prior to transmitting the Sync sequence.	$145+10*UI$	-	-	ns
T_{EOT}	Transmitted time interval from the start of $T_{HS-TRAIL}$ or $T_{CLK-TRAIL}$, to the start of the LP-11 state following a HS burst.	-	-	$105ns+12*UI$	ns
$T_{HS-TRAIL}$	Time that the transmitter drives the flipped differential state after last payload data bit of a HS transmission burst.	$60ns+4*UI$	-	-	ns
T_{HS-EXT}	Time that the transmitter drives LP-11 following a HS burst.	100	-	-	ns

Table 4.4: Global operation timing parameters for data lane

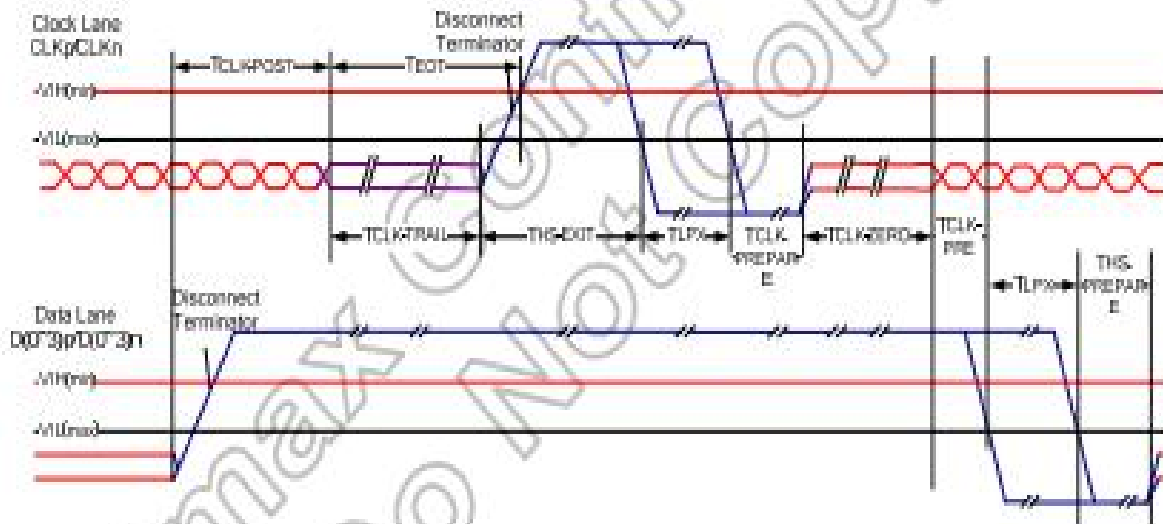

Figure 4.19: Switching the clock lane between clock transmission and LP mode



DATA SHEET 001

Parameter	Description	Spec.			Unit
		Min.	Typ.	Max.	
$T_{CLK-POST}$	Time that the transmitter continues to send HS clock after the last associated Data Lane has transitioned to LP Mode.	$60+52*UI$	-	-	ns
$T_{CLK-TRAIL}$	Time that the transmitter drives the flipped differential state after last payload data bit of a HS transmission burst.	60	-	-	ns
$T_{CLK-PREPARE}$	Time that the HS clock shall be driven by the transmitter prior to any associated Data Lane beginning the transition from LP to HS mode.	38	-	95	ns
$T_{CLK-PREPARE}+T_{CLK-ZERO}$	$T_{CLK-PREPARE}$ + time that the transmitter drives the HS-0 state prior to starting the Clock.	300	-	-	ns
$T_{CLK-PRE}$	Time that the HS clock shall be driven by the transmitter prior to any associated Data Lane beginning the transition from LP to HS mode.	$8*UI$	-	-	ns

Table 4.5: Global operation timing parameters for clock lane



5. OPTICAL CHARACTERISTICS

(LCD MONOMER PARAMETERS)

Item	Symbol	Condition	Specification			Unit	Remark
			Min.	Typ.	Max.		
Response Time (By Quick)	Tr+Tf	$\theta = 0^\circ$	-	35	45	ms	Note 5
Contrast Ratio	CR	$\theta = 0^\circ$	700	1000	-		Note 2,6
Viewing Angle	Top	$CR \geq 10$	75	80	-	deg.	Note 2,5,7
	Bottom	$CR \geq 10$	75	80	-		
	Left	$CR \geq 10$	75	80	-		
	Right	$CR \geq 10$	75	80	-		
Color Chromaticity	Wx	$\theta = 0^\circ$	-0.03	0.299	+0.03		Note3
	Wy			0.316			
NTSC		$\theta = 0^\circ$	60	70			Note3
Transmittance	Trans		3.6	4.2	-	%	Note 4, 9



Note 1: Ambient temperature = 25°C.

Note 2: To be measured with a viewing cone of 2° by Topcon luminance meter BM-5A.

Note 3: To be measured with Otsuka chromaticity meter LCF-2100M, CF only measure under the simulation of C-light

Note 4: Transmittance of Specification is cell with polarizer

Note 5: Definition of response time:

The output signals of TRD-100 are measured when the input signals are changed to "White" (falling time) and from "White" to "Black" (rising time), respectively. The interval is between the 10% and 90% of amplitudes. Refer to figure as below.

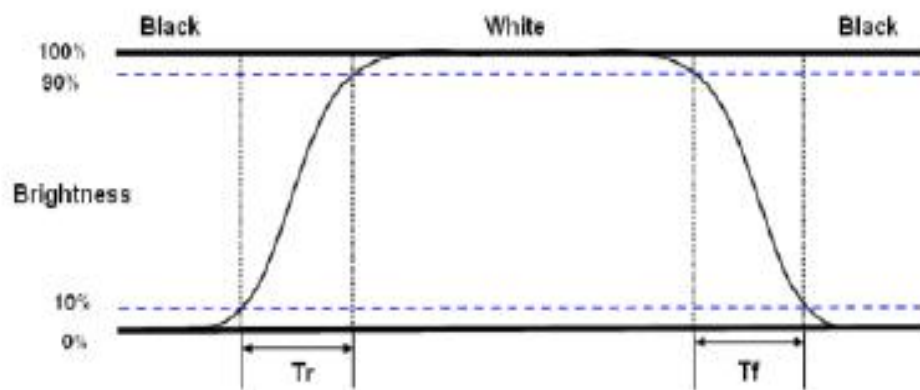

Note 6: Definition of contrast ratio:

Contrast ratio is calculated by the following formula.

$$\text{Contrast ratio (CR)} = \frac{\text{LCM center brightness on the "white" state}}{\text{LCM center brightness on the "black" state}}$$

Note 7: Definition of viewing angle

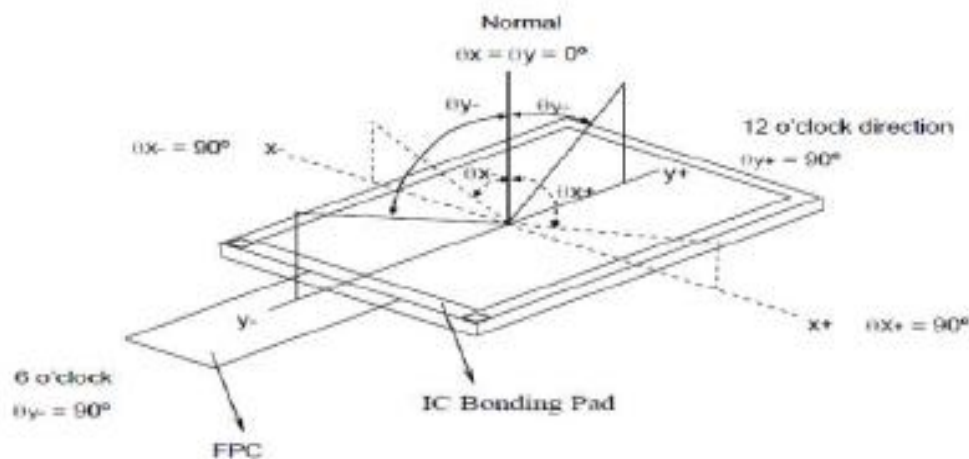



Note 8: Optical characteristic measurement setup.

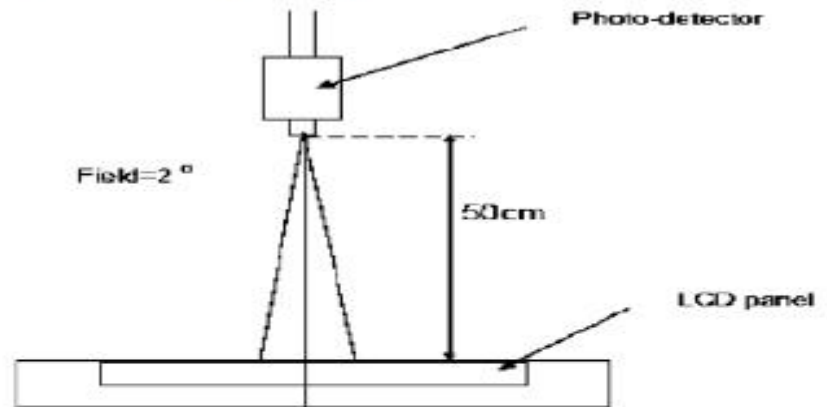

Note 9: Definition of transmittance:

Tr is calculated by the following formula.

$$Tr = 100\% \times \frac{\text{Brightness of LCM center}}{\text{Brightness of backlight center}}$$



6. QUALITY SPECIFICATIONS

1. Inspection condition

6.1.1:Cosmetic inspection: viewing distance is about 30cm with bare eyes, and under an environment of 20~40W light intensity (600~1200LUX) , all

perpendicular line.

6.1.2:Function inspection: viewing distance is about 30cm with bare eyes, and under an environment of 300LUX light intensity, all directions for inspecting the sample should be within 45° against perpendicular line.

2. Definition of Inspection Item.

2.1 Definition of Inspection zone in I-touch module.

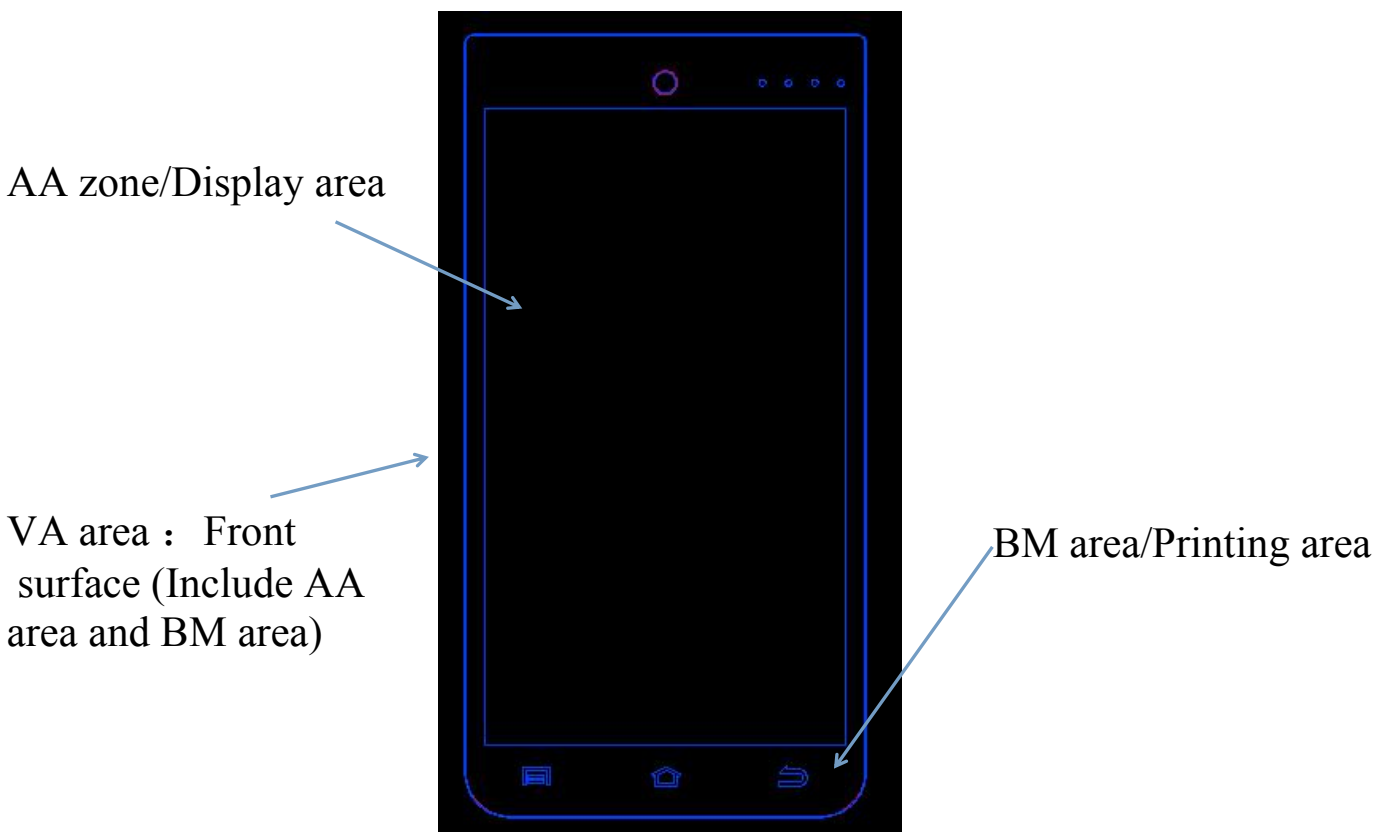

AA zone: Character/Display area

BM zone: Printing area

VA zone: Viewing area (AA area + BM area = viewing area)



3. Defect definition

3.1 Circular defect

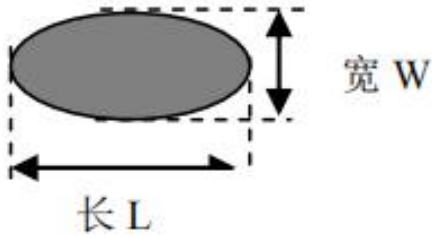

Diameter $\Phi = 1/2(L+W)$

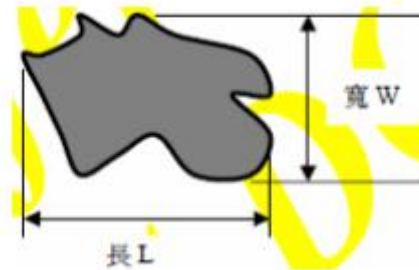

Diameter $\Phi = 1/2(L+W)$

3.2 Linear defect

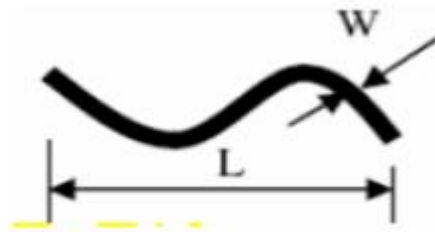

3.3 Pin hole

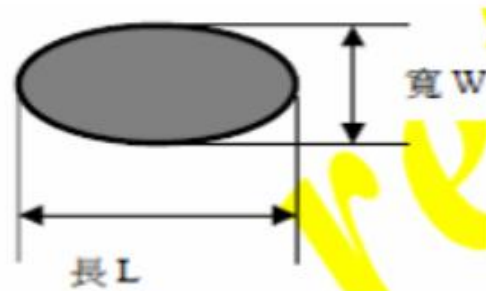
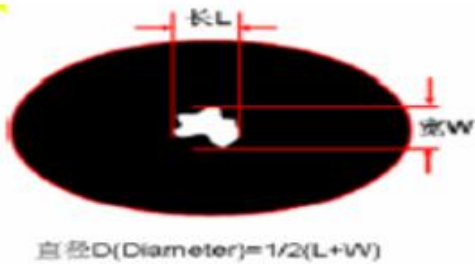

3.4 Zigzag

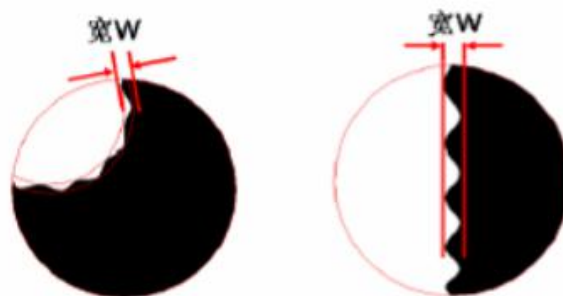



4. Inspection standards

4.1 Major defect

-Item -No	Items to be inspected	Inspection Standard	Classification of defects
4.1.1	All functional defects	1) No display 2) Display abnormally 3) Missing vertical, horizontal segment 4) Short circuit 5) Back-light no lighting, flickering and abnormal lighting. 6) Touch panel abnormal.	Major
4.1.2	Missing	Missing component	
4.1.3	Outline dimension	Overall outline dimension beyond the drawing is not allowed.	
4.1.4	LCD Mura	LCD Mura according to ND 5% keep out to determine, if keep out distance at 30cm be seen by eyes is NG, otherwise will be ok if invisible.	

4.2 Cosmetic defect

Item No	Items to be inspected	Inspection Standard	Classification of defects										
4.2.1	Dot defect	<table border="1"> <thead> <tr> <th>Zone Size(mm)</th> <th>VA area Acceptable Qty</th> </tr> </thead> <tbody> <tr> <td>$\Phi \leq 0.1$</td> <td>Ignore</td> </tr> <tr> <td>$0.10 < \Phi \leq 0.15$</td> <td>1</td> </tr> <tr> <td>$0.15 < \Phi \leq 0.20$</td> <td>1</td> </tr> <tr> <td>$0.20 < \Phi$</td> <td>0</td> </tr> </tbody> </table>	Zone Size(mm)	VA area Acceptable Qty	$\Phi \leq 0.1$	Ignore	$0.10 < \Phi \leq 0.15$	1	$0.15 < \Phi \leq 0.20$	1	$0.20 < \Phi$	0	Minor
Zone Size(mm)	VA area Acceptable Qty												
$\Phi \leq 0.1$	Ignore												
$0.10 < \Phi \leq 0.15$	1												
$0.15 < \Phi \leq 0.20$	1												
$0.20 < \Phi$	0												





4.2.2	Dim Spots: Circle shaped and dim edged defects	<table border="1"> <thead> <tr> <th colspan="2" data-bbox="515 293 826 371">Zone</th> <th data-bbox="826 293 1166 371">VA area</th> </tr> <tr> <th colspan="2" data-bbox="515 371 826 479">Size(mm)</th> <th data-bbox="826 371 1166 479">Acceptable Qty</th> </tr> </thead> <tbody> <tr> <td colspan="2" data-bbox="515 479 826 533">$\Phi \leq 0.10$</td> <td data-bbox="826 479 1166 533">Ignore</td> </tr> <tr> <td colspan="2" data-bbox="515 533 826 586">$0.10 < \Phi \leq 0.15$</td> <td data-bbox="826 533 1166 586">1</td> </tr> <tr> <td colspan="2" data-bbox="515 586 826 640">$0.15 < \Phi \leq 0.20$</td> <td data-bbox="826 586 1166 640">1</td> </tr> <tr> <td colspan="2" data-bbox="515 640 826 705">$0.20 < \Phi$</td> <td data-bbox="826 640 1166 705">0</td> </tr> </tbody> </table>	Zone		VA area	Size(mm)		Acceptable Qty	$\Phi \leq 0.10$		Ignore	$0.10 < \Phi \leq 0.15$		1	$0.15 < \Phi \leq 0.20$		1	$0.20 < \Phi$		0	Minor
Zone		VA area																			
Size(mm)		Acceptable Qty																			
$\Phi \leq 0.10$		Ignore																			
$0.10 < \Phi \leq 0.15$		1																			
$0.15 < \Phi \leq 0.20$		1																			
$0.20 < \Phi$		0																			
Item No	Items to be inspected	Inspection Standard	Classification of defects																		
4.2.3	Dent Spot Fish eye	<table border="1"> <thead> <tr> <th colspan="2" data-bbox="491 943 839 1010">Zone</th> <th data-bbox="839 943 1190 1010">VA area</th> </tr> <tr> <th colspan="2" data-bbox="491 1010 839 1093">Size(mm)</th> <th data-bbox="839 1010 1190 1093">Acceptable Qty</th> </tr> </thead> <tbody> <tr> <td colspan="2" data-bbox="491 1093 839 1146">$\Phi \leq 0.10$</td> <td data-bbox="839 1093 1190 1146">Ignore</td> </tr> <tr> <td colspan="2" data-bbox="491 1146 839 1200">$0.10 < \Phi \leq 0.15$</td> <td data-bbox="839 1146 1190 1200">1</td> </tr> <tr> <td colspan="2" data-bbox="491 1200 839 1254">$0.15 < \Phi \leq 0.20$</td> <td data-bbox="839 1200 1190 1254">1</td> </tr> <tr> <td colspan="2" data-bbox="491 1254 839 1308">$0.20 < \Phi$</td> <td data-bbox="839 1254 1190 1308">0</td> </tr> </tbody> </table>	Zone		VA area	Size(mm)		Acceptable Qty	$\Phi \leq 0.10$		Ignore	$0.10 < \Phi \leq 0.15$		1	$0.15 < \Phi \leq 0.20$		1	$0.20 < \Phi$		0	Minor
Zone		VA area																			
Size(mm)		Acceptable Qty																			
$\Phi \leq 0.10$		Ignore																			
$0.10 < \Phi \leq 0.15$		1																			
$0.15 < \Phi \leq 0.20$		1																			
$0.20 < \Phi$		0																			
4.2.4	Line defect	<table border="1"> <thead> <tr> <th colspan="2" data-bbox="491 1391 967 1458">Zone</th> <th data-bbox="967 1391 1193 1458">VA area</th> </tr> <tr> <th data-bbox="491 1458 683 1503">L</th> <th data-bbox="683 1458 967 1503">W</th> <th data-bbox="967 1458 1193 1503">Acceptable Qty</th> </tr> <tr> <th data-bbox="491 1503 683 1570">(Length)</th> <th data-bbox="683 1503 967 1570">(Width)</th> <th data-bbox="967 1503 1193 1570"></th> </tr> </thead> <tbody> <tr> <td data-bbox="491 1570 683 1630">Ignore</td> <td data-bbox="683 1570 967 1630">$W \leq 0.03$</td> <td data-bbox="967 1570 1193 1630">Ignore</td> </tr> <tr> <td data-bbox="491 1630 683 1691">$L \leq 2.0$</td> <td data-bbox="683 1630 967 1691">$0.03 < W \leq 0.05$</td> <td data-bbox="967 1630 1193 1691">1</td> </tr> <tr> <td data-bbox="491 1691 683 1765">/</td> <td data-bbox="683 1691 967 1765">$0.05 < W$</td> <td data-bbox="967 1691 1193 1765">Define as spot defect</td> </tr> </tbody> </table>	Zone		VA area	L	W	Acceptable Qty	(Length)	(Width)		Ignore	$W \leq 0.03$	Ignore	$L \leq 2.0$	$0.03 < W \leq 0.05$	1	/	$0.05 < W$	Define as spot defect	Minor
Zone		VA area																			
L	W	Acceptable Qty																			
(Length)	(Width)																				
Ignore	$W \leq 0.03$	Ignore																			
$L \leq 2.0$	$0.03 < W \leq 0.05$	1																			
/	$0.05 < W$	Define as spot defect																			



4.2.5	Scratch	<p>If the scratch can be seen after mobile phone cover assembling or in the operating condition, judged as the line defect of 4.2.4.</p> <p>If the scratch can be seen only in non-operating condition or some special angle, judged as the following table.</p>			Minor
		Size (mm)		VA area	
		L (Length)	Acceptable Qty	Acceptable Qty	
		Ignore	$W \leq 0.03$	Ignore	
		$L \leq 2.0$	$0.03 < W \leq 0.05$	1	
/	$0.05 < W$	Define as spot defect			

Item No	Items to be inspected	Inspection Standard	Classification of defect									
4.2.6	Bubble (Except that the CTP fit bubbles)	<table border="1"> <thead> <tr> <th rowspan="2">Zone Size(mm)</th> <th>VA area</th> </tr> <tr> <th>Acceptable Qty</th> </tr> </thead> <tbody> <tr> <td>$\Phi \leq 0.15$</td> <td>0</td> </tr> <tr> <td>$0.15 < \Phi \leq 0.25$</td> <td>0</td> </tr> <tr> <td>$0.25 < \Phi$</td> <td>0</td> </tr> </tbody> </table>	Zone Size(mm)	VA area	Acceptable Qty	$\Phi \leq 0.15$	0	$0.15 < \Phi \leq 0.25$	0	$0.25 < \Phi$	0	Minor
Zone Size(mm)	VA area											
	Acceptable Qty											
$\Phi \leq 0.15$	0											
$0.15 < \Phi \leq 0.25$	0											
$0.25 < \Phi$	0											
4.2.7	Glass defect	<p>Cracks tend to break are not allowed.</p>										



4.2.8	Parts alignment	<p>1) Not allow IC and FPC/heat-seal lead width is more than 50% beyond lead pattern.</p> <p>2) Not allow chip or solder component is off center more than 50% of the pad outline.</p>	Minor
4.2.9 view area/ printing area of front surface and view area of rear surface	LOGO Pattern	 <p>Dot: according to Dot spec. Thickness odds:</p> $\frac{ \text{Spec pattern width} - \text{Print pattern width} \times 100\%}{\text{Spec pattern width}} \leq 30\%$ <p>Drawing slant:</p> <p>Print pattern length $\leq 10\text{mm}$, slant angle $\leq 3^\circ$; $10\text{mm} < \text{Print pattern length} \leq 20\text{mm}$, slant angle $\leq 1.5^\circ$</p>  <p>Pattern serration: $H \leq 0.05 \text{ mm}$</p> <p>Pattern leak print/ error/overprint: not allowed</p> <p>Pattern break line: width $\leq 0.10 \text{ mm}$</p> <p>Logo pattern color windage / color thin: Follow the limit samples.</p>	Minor



Item No	Items to be inspected	Inspection Standard	Classification of defects
4.2.10 view area/print ing area of front surface and view area of rear surface	IR hole(A)/ Light sensor hole(B)/ LED hole(C)	 <ol style="list-style-type: none"> 1. A.B.C hole must be according the transmittancy 2. Light leakage on A.B.C hole or follow the limited sample. 3. A.B.C hole (LED) hole only judge by black background, no need to check in the lamb condition. 	Minor
	Surface dirty	<ol style="list-style-type: none"> 1. Dirty can not be cleaned follow the dot spec. 2. Accept while the dirty can be cleaned. 3. The quality guarantee period of protective film is 3months, during the period, the spot or contamination is not allowed. 	
	Printing area Light leakage	Follow the dot defect spec, MAX, Severity - see light leakage limit sample	
	Ink overflow	Visual inspection 30cm not allowed	
	Color discordant	Obvious color difference in the BM area is not allowed	
	Icon scratch of printing logo area	Icon printing logo area is not allow penetrability scratch	



7.RELIABILITY

Test Item	Test Condition	Inspection after test
High Temperature Operation	70°C for 96 hours	Inspection after 2~4hours storage at room temperature, the sample shall be free from defects: 试验结束后, 已测试的 LCD 样品必须在室内正常温湿度环境下放置 2~4 个小时以上才能进行功能和外观检查, 样品不允许有以下缺陷: 1. 无功能不良, 例: 缺划, 显异, 严重爆灯等 2. 外观无偏光片气泡, OCA 气泡等不良: 2. The test samples should be applied to only one test item. 每个被测试的模块只能用于其中的一个测试项目。
Low Temperature Operation	-20°C for 96 hours	
High Temperature Storage	80°C for 96 hours	
Low Temperature Storage	-30°C for 96 hours	
High Temperature Storage Humidity Storage	60°C, 90%RH for 72 hours	
Thermal Shock	-10°C (30min) ~+25°C (5min)~ +60°C (30min) for 10 cycles	
Vibration Test (No Operation)	Frequency: 10~55Hz Amplitude:1.0mm Sweep Time: 11min Test Period: 6 Cycles for each direction of X, Y, Z	
Static electricity test	Touch ±4KV, air touch ±8KV	



8. HANDLING PRECAUTION

8.1 SAFETY

- (1) Do not swallow any liquid crystal, even if there is no proof that liquid crystal is poisonous.
- (2) If the LCD panel breaks, be careful not to get liquid crystal to touch your skin.
- (3) If skin is exposed to liquid crystal, wash the area thoroughly with alcohol or soap.

8.2 STORAGE CONDITIONS

- (1) Store the panel or module in a dark place where the temperature is $23\pm 5^{\circ}\text{C}$ and the humidity is below $50\pm 20\% \text{RH}$.
- (2) Store in anti-static electricity container.
- (3) Store in clean environment, free from dust, active gas, and solvent.
- (4) Do not place the module near organics solvents or corrosive gases.
- (5) Do not crush, shake, or jolt the module.

8.3 HANDLING PRECAUTIONS

- (1) Avoid static electricity which can damage the CMOS LSI.
- (2) The polarizing plate of the display is very fragile. So, please handle it very carefully.
- (3) Do not give external shock.
- (4) Do not apply excessive force on the surface.
- (5) Do not wipe the polarizing plate with a dry cloth, as it may easily scratch the surface of plate.
- (6) Do not use ketonic solvent & Aromatic solvent, use with a soft cloth soaked with a cleaning naphtha solvent.
- (7) Do not operate it above the absolute maximum rating.
- (8) Do not remove the panel or frame from the module.

8.4 WARRANTY

- 1) From the Kingtech shipping date, customers need to be up and running within 6 months. 从Kingtech发货之日起, 客户需要6个月内上线并且使用。
- 2) According to Kingtech TFT LCD quality standard, Kingtech will rework or exchange for functional defect goods sine within one year. 依据Kingtech TFT LCD质量标准, Kingtech将在一年内保修或置换功能缺陷产品。
- 3) strictly prohibit the display in the whole machine for a long time point a fixed screen (display by the LCD residual shadow determination criteria); suggest that the entire machine more than 2 minutes without the use of LCM automatically into hibernation, more than 30 minutes without the use of the system to force LCM into hibernation. 严禁显示屏在整机长期点一个固定画面(显示屏依LCD残影判定标准); 建议整机超过2分钟不使用LCM自动进入休眠, 超过30分钟不使用系统强制LCM进入休眠



状态。

4) Display is strictly prohibited to work continuously for more than 8 hours on the whole machine. 严禁显示屏在整机连续工作8小时以上。

5) Please take the module under static protection. 请在有静电防护情况下，拿取模组。

LCM in special scenarios (such as high concentration of chemicals, strong magnetic field, extreme cold, and other use scenarios) use in advance to contact us to confirm. LCM在特殊场景（比如高浓度化学品，强磁场，极寒等使用场景）使用时提前联系我们确认。



9. PACKAGE DRAWING

保存期限: 三年

版本号: A/1

表格受控编号:

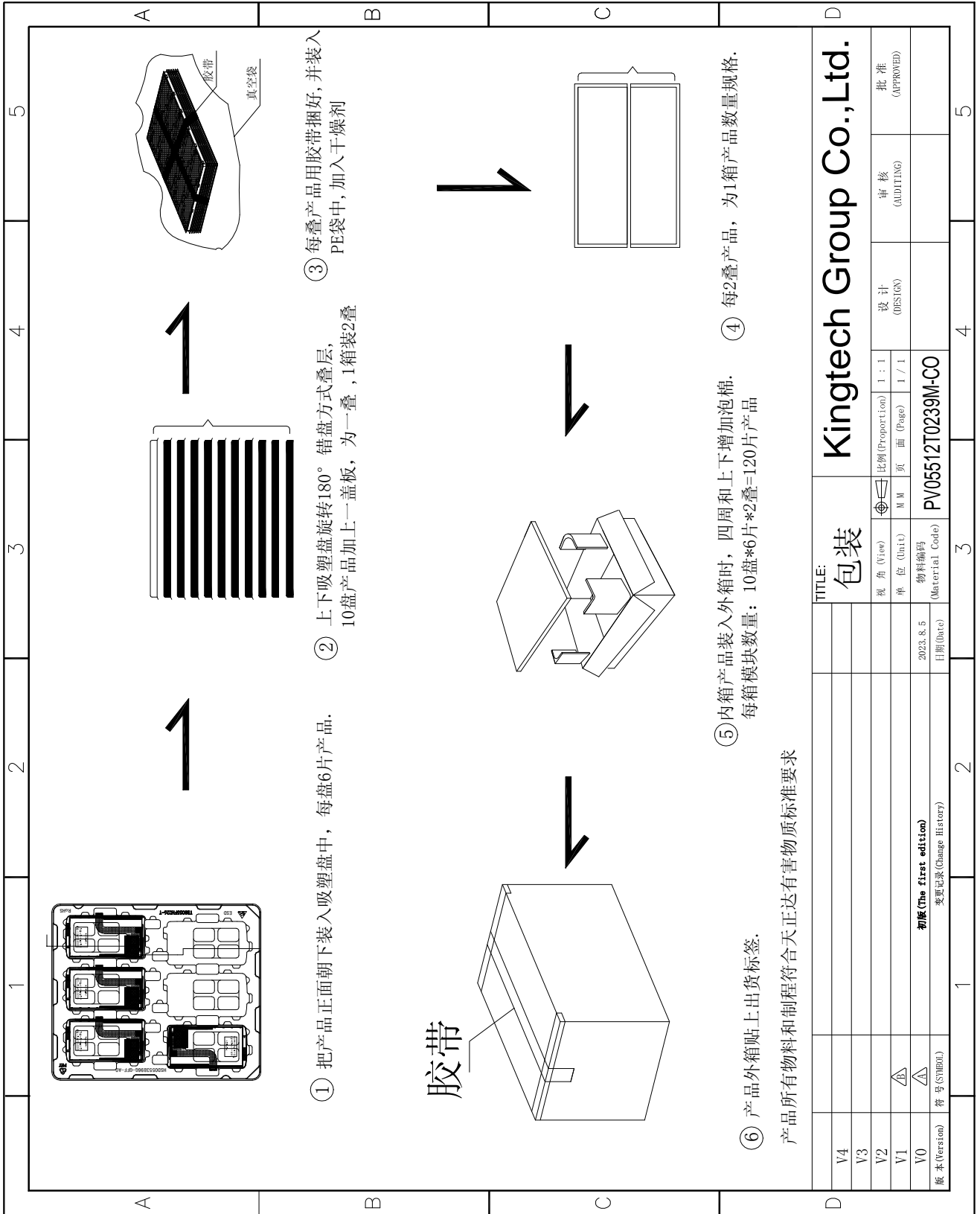

TITLE: 包装		Kingtech Group Co., Ltd.	
视图 (View)	M M	比例 (Proportion)	1 : 1
单位 (Unit)		页 面 (Page)	1 / 1
物料编号 (Material Code)	PV05512T0239M-CO		
日期 (Date)	2023.8.5	设计 (DESIGN)	
变更记录 (Change History)	初版 (The first edition)		
符号 (SYMBOL)		审核 (AUDITING)	
		批准 (APPROVED)	



11. 关键材料

PV05512T0239-CO								
供货状态:	LCD+IC+FPC+B/L+OCA全贴合+CTP							
序号	材料名称	原产地	规格	单品用量	单位	制造商名称	适用项目	备注
1	LCD		5.5' FHD 分辨率1080*1920 IPS 0.2T	1	PCS			
2	Drive IC		HX8399	1	PCS			
3	FPC		无胶电解铜 双面EMI/TS8055HD040-T V1.2	1	PCS			
4	B/L		LED : 8串2并	1	PCS			
5	OCA		0.175mm 光学OCA	1	PCS			
6	POL		上:0.13MM细沙 下:0.13光片带增亮	2	PCS			
7	CTP Lens		康宁3代 0.7MM 光学盖板 带AF (防指纹处理)	1	PCS			
8	CTP IC		GT1151QM 支持10点触摸	1	PCS			

第 1 页



12.实验报告

可靠性实验报告

物料名称:	液晶显示模组	物料型号:	/	供应商:	/
应用型号:	PV05512T0239-CO	版本:	A0	送验数量:	各 2PCS
送验时间:	2023-8-25	状态:	模组总成	送验人:	李鑫
实验目的:	成品可靠性试验验证			完成时间:	2023-8-30
实验项目:					
操作温度高温 <input checked="" type="checkbox"/>		操作温度低温 <input checked="" type="checkbox"/>		恒温恒湿 <input checked="" type="checkbox"/>	
高温存储 <input checked="" type="checkbox"/>		低温存储 <input checked="" type="checkbox"/>		冷热冲击 <input checked="" type="checkbox"/>	
振动 <input checked="" type="checkbox"/>		FPC 测试 <input type="checkbox"/>		高温老化 <input type="checkbox"/>	
ESD 静电抗性 <input checked="" type="checkbox"/>		光学测试 <input type="checkbox"/>		盐雾实验 <input type="checkbox"/>	
钢球跌落 <input checked="" type="checkbox"/>					

实验项目	数量	设备	实验条件	结果	测试人/时间	备注(实验设备条件)
高温操作	2	恒温恒湿机	1. 温度: 70°C 时间: 96H 2. 测试结束后常温 2H 后确认	OK	谭梅燕 2023-8-29	
低温操作	2	恒温恒湿机	1. 温度: -20°C 时间: 96H 2. 测试结束后常温 2H 后确认	OK	谭梅燕 2023-8-29	
高温存储	2	恒温恒湿机	3. 温度: 80°C 时间: 96H 4. 测试结束后常温 2H 后确认	OK	谭梅燕 2023-8-29	
低温存储	2	恒温恒湿机	3. 温度: -30°C 时间: 96H 4. 测试结束后常温 2H 后确认	OK	谭梅燕 2023-8-29	
恒温恒湿操作	2	恒温恒湿机	1. 温度: 60°C 湿度: 90% 2. 测试时间: 72H (常温 2H 后确认)	OK	谭梅燕 2023-8-28	
冷热冲击	2	冷热冲击机	冷热冲击实验 [-10°C (30MIN) ~ +25°C (5MIN) ~ +60°C (30min) for 10cycles]	OK	谭梅燕 2023-8-26	
振动	80 (整箱)	振动机	1. 频率: 10~55Hz, 2. 振幅: 1MM, 3. 时间: 每个方向振动十分钟(X,Y,Z 各 6 次)	OK	谭梅燕 2023-8-25	



ESD 静电抗性	2	静电放电抗扰度测试仪	1.湿度 25%--75% 2. 接触放电: ±4 KV 次数: 10 试验品数量: 2 空气放电: ±8 KV 次数: 10 试验品数量: 2	OK	谭梅燕 2023-8-29	
高温老化测试	80	老化房	1.温度: 50℃ 时间: 8H 2.测试时间: 常温 2H后确认	OK	陈少君 2023-8-25	
钢球跌落	2	钢球跌落实验机	1.显示屏: 67g 钢球 高度: 50cm 10 次	OK	谭梅燕 2023-8-25	

审核: 陈厚高