



Kingtech Group Co.,Ltd

TFT LCD Display Datasheet

PV104007R0240H REV 1.0



Revision History

REVISION	DATE	COMMENT	REMARKS
1.0	09/09/2019	Initial Draft	Initial Draft Version

Table of Contents

- 1. General Specification3
- 2. TFT LCD Display Drawing.....4
- 3. Absolute Maximum Ratings5
- 4. DC Characteristics5
- 5. Electro-Optical Characteristics.....5
- 6. Backlight Characteristics6
- 7. Interface Descriptions.....7
- 8. Timing Characteristics.....8
 - 8.1. Power Sequence8
 - 8.2. AC Electrical Characteristics9
 - 8.3. Data Input Format.....10
 - 8.4. Timing11
- 9. Reliability Test12
- 10. Precautions for Using LCD Module13
 - 10.1. Handling Precautions13
 - 10.2. Storage Precautions13
 - 10.3. Others14
- 11. Legal Information.....15



1. General Specification

PV104007R0240H is a colour active-matrix LCD module incorporating amorphous silicon TFT (Thin Film Transistor). It is composed of a colour TFT-LCD panel, driver IC, FPC and a back light unit. The module display area contains 1024 x 100 pixels. This product accords with RoHS environmental criterion.

ITEM	CONTENTS	UNIT
LCD Type	TFT / Transmissive / Normally White	
Size	10.4	Inch
Viewing Direction	80/80/80/80	O'Clock
Display Mode	Nomally White	
LCD (W × H × T)	274.92 × 41.5 × 3.5	mm ³
Active Area (W × H)	264.192 × 25.8	mm ²
Dot Pitch (W × H)	0.258 × 0.258	mm ²
Number of Dots (Pixels)	1024 (RGB) × 100	
Surface Luminance	950 (typical)	cd/m ²
Interface Type	TTL	
Pixel Arrangement	RGB Vertical Stripe	
Operating Temperature	-20~70	°C
Storage Temperature	-30~80	°C
With/Without TP	NMLCD-1041024100 - - Without Touch	

Note 1: RoHS compliant

Note 2: LCD weight tolerance: ± 5%.

Part Number Details:

NMLCD	TFT LCD
104	10.4 inch
1024100	1024 × 100 Resolution

2. TFT LCD Display Drawing

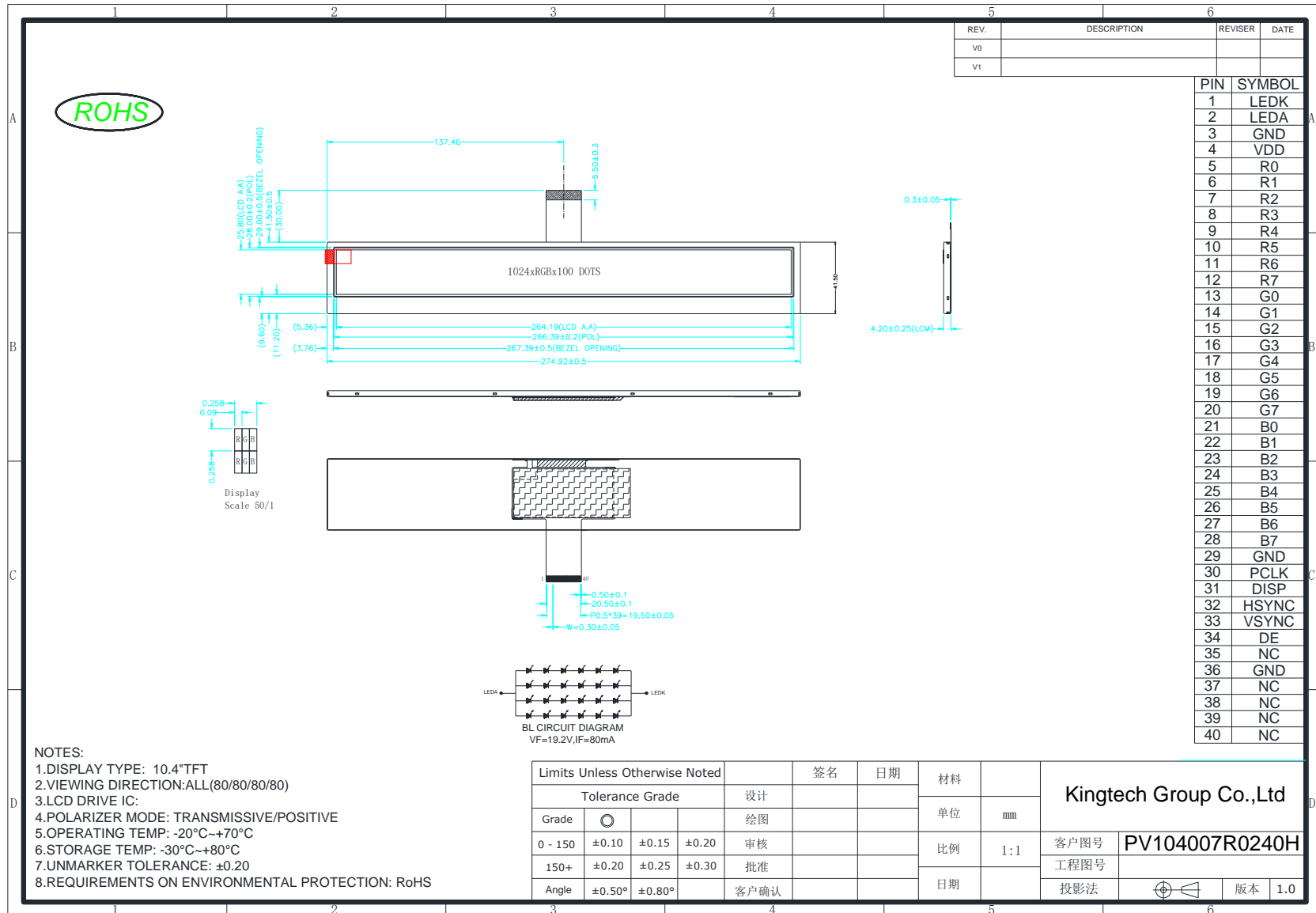



3. Absolute Maximum Ratings

PARAMETER	SYMBOL	MIN	MAX	UNIT
Digital Supply Voltage	DVDD	-0.3	5	V
Operating Temperature	TOP	-20	70	°C
Storage Temperature	TST	-30	80	°C
Humidity	HD	20	90	%RH

4. DC Characteristics

PARAMETER	SYMBOL	MIN	TYP	MAX	UNIT
Digital Supply Voltage	DVDD	3.0	3.3	3.6	V
Input Current	DVDD	-	150	280	mA
Input Voltage 'H' Level	VIH	0.7DVDD	-	DVDD	V
Input Voltage 'L' Level	VIL	GND	-	0.3DVDD	V

5. Electro-Optical Characteristics

ITEM	SYM	CONDITION	MIN	TYP	MAX	UNIT	REMARK
Response Time	Tr+Tf	$\theta=0$	-	25	-	ms	(1)(4)(6)
Contrast Ratio	Cr	°	-	300	-	-	(1)(3)(6)
Surface Luminance	Lv	NMLCD-1041024100	-	950	-	cd/m ²	
Viewing Angle Range	θ	$\phi = 90^\circ$	-	80	-	deg	(1)(2)(6)
		$\phi = 270^\circ$	-	80	-	deg	
		$\phi = 0^\circ$	-	80	-	deg	
		$\phi = 180^\circ$	-	80	-	deg	
CIE (x,y) Chromacity	Red	x	$\theta=0^\circ$ $\phi=0^\circ$ Ta=25	-	-0.05	+0.05	(1)(6)
		y		-			
	Green	x		-			
		y		-			
	Blue	x		-			
		y		-			
White	x	-					
	y	-					

Note (1) Measurement Setup: The LCD module should be stabilized at given temp. 25°C for 15 minutes to avoid abrupt temperature change during measuring. In order to stabilize the luminance, the measurement should be executed after lighting backlight for 15 minutes in a windless room.

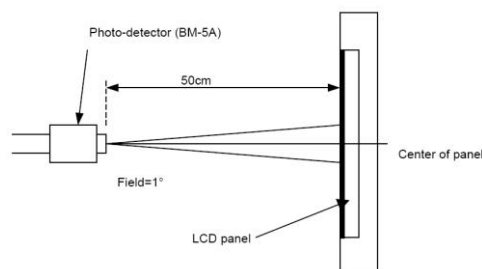



Note (2) Definition of Viewing Angle

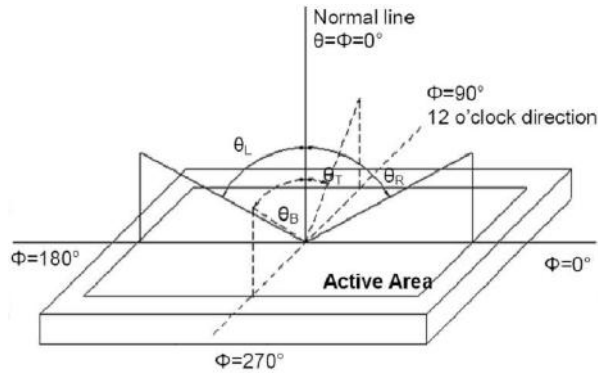

Note (3) Definition of Contrast Ratio (CR) The contrast ratio can be calculated by the following expression

$$\text{Contrast Ratio (CR)} = L_{63} / L_0$$

L₆₃: Luminance of gray level 63

L₀: Luminance of gray level 0

Note (4) Definition of response time

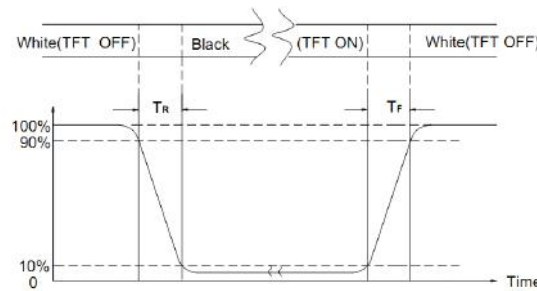

Note (5) Definition of Transmittance (Module is without signal input)

$$\text{Transmittance} = \text{Center Luminance of LCD} / \text{Center Luminance of Back Light} \times 100\%$$

Note (6) Definition of colour chromaticity (CIE1931)

Colour coordinates measured at the center point of LCD

6. Backlight Characteristics

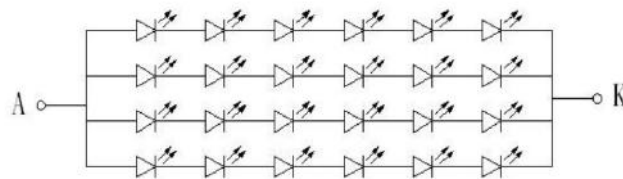

LED 電路圖

PARAMETER	SYMBOL	MIN	TYP	MAX	UNIT	CONDITION
Voltage for LED Backlight	V _f	17	19.2	21.6	V	I _f =80mA
Current for LED Backlight	I _f	-	80	-	mA	
Luminous Intensity for LCM	-	800	950	-	cd/m ²	
Uniformity for LCM	-	80	-	-	%	
LED Life Time	-	-	50000	-	Hrs	



7. Interface Descriptions

PIN NO.	SYMBOL	DESCRIPTION
1	LEDK	LED Backlight (Cathode)
2	LEDA	LED Backlight (Anode)
3	GND	Ground
4	VDD	Power Supply
5~12	R0~R7	Red Data
13~20	G0~G7	Green Data
21~28	B0~B7	Blue Data
29	GND	Ground
30	DCLK	Clock
31	DISP	Display On/Off
32	HSYNC	Horizontal Sync Input in RGB Mode
33	VSYNC	Vertical Sync Input in RGB Mode
34	DE	Data enable input. Active high to enable the input data bus
35	NC	No Connection
36	GND	Ground
37~40	NC	No Connection



8. Timing Characteristics

8.1. Power Sequence

a. Power on:

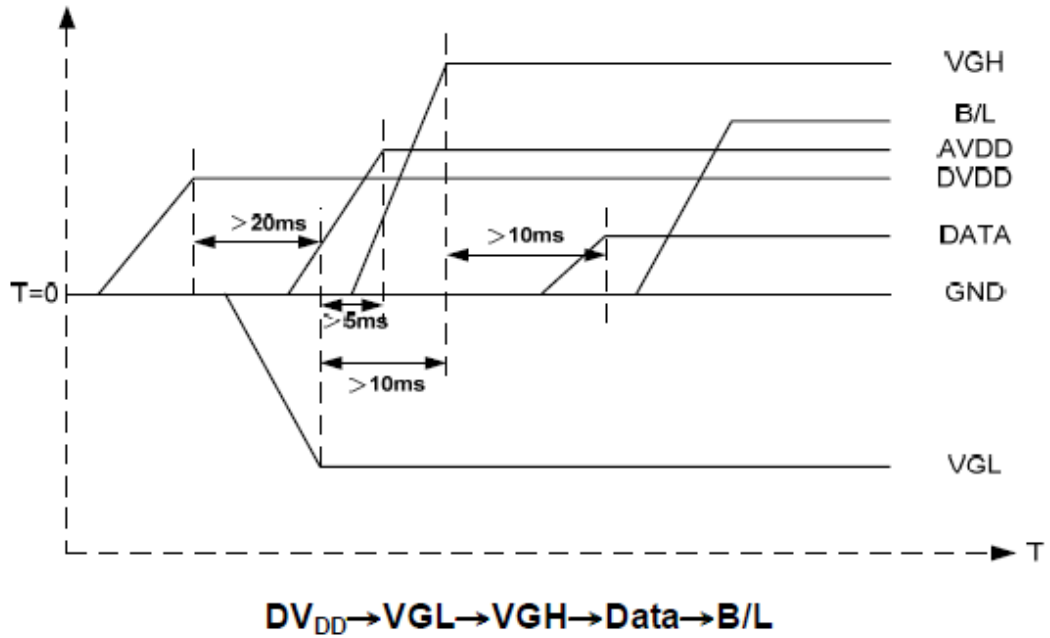

b. Power off:

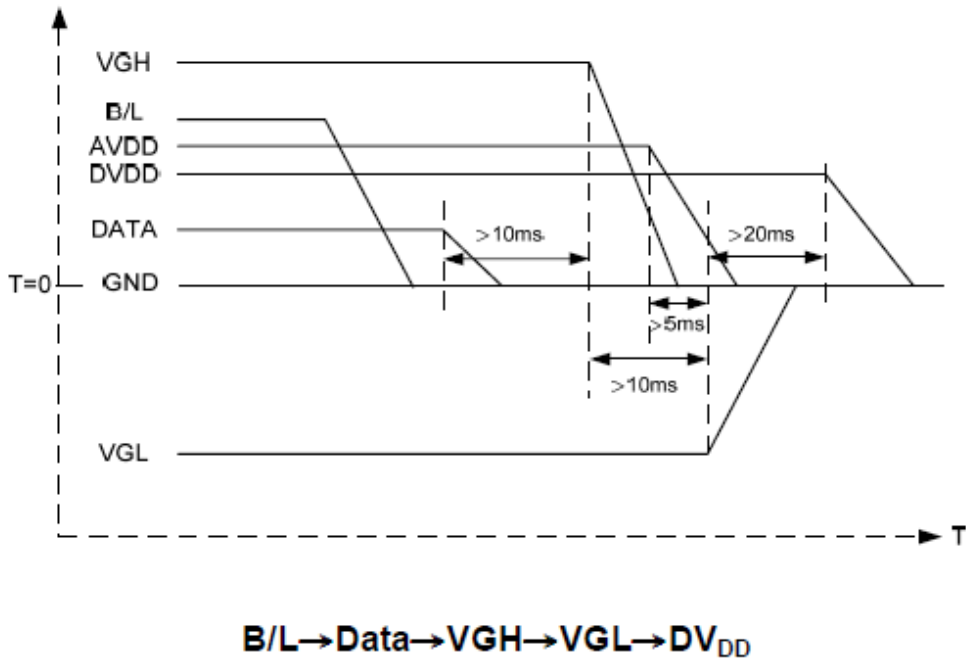

Note: Data include R0~R7, B0~B7, GO~G7, U/D, L/R, DCLK, HS, VS, DE.



8.2. AC Electrical Characteristics

Item	Symbol	Values			Unit	Remark
		Min.	Typ.	Max.		
HS setup time	T_{hst}	8	-	-	ns	
HS hold time	T_{hhd}	8	-	-	ns	
VS setup time	T_{vst}	8	-	-	ns	
VS hold time	T_{vhd}	8	-	-	ns	
Data setup time	T_{dsu}	8	-	-	ns	
Data hole time	T_{dhd}	8	-	-	ns	
DE setup time	T_{esu}	8	-	-	ns	
DE hole time	T_{ehd}	8	-	-	ns	
DV _{DD} Power On Slew rate	T_{POR}	-	-	20	ms	From 0 to 90% DV _{DD}
RESET pulse width	T_{Rst}	1	-	-	ms	
DCLK cycle time	T_{coh}	20	-	-	ns	
DCLK pulse duty	T_{cwh}	40	50	60	%	

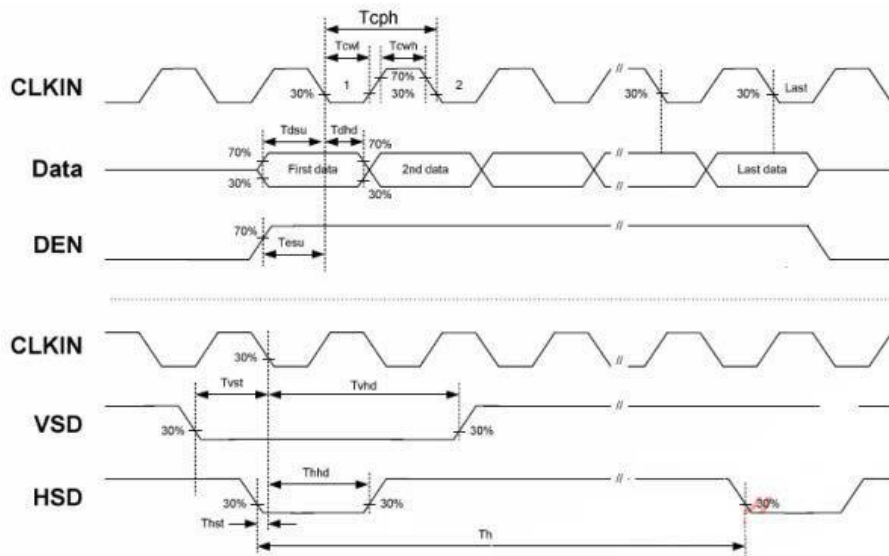



8.3. Data Input Format

Horizontal Input Timing Diagram



Vertical Input Timing Diagram

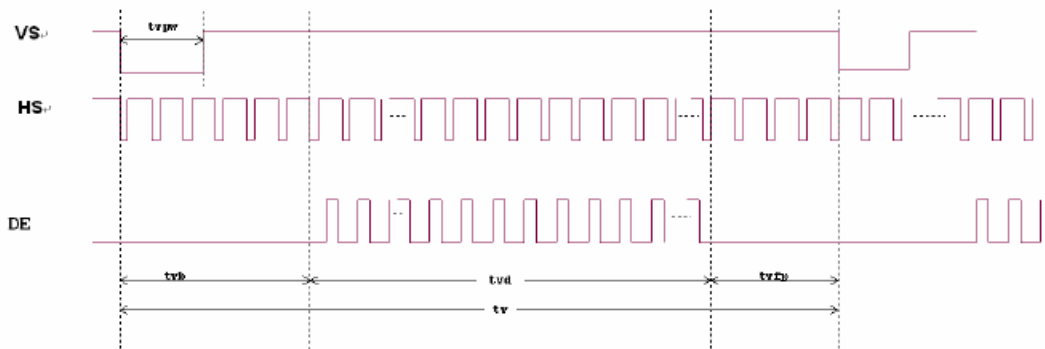



8.4. Timing

DCLK latch => Falling latch



(UD=H , LR=H) 正掃(左上到右下)

Timing Table HX8282A		SYNC MODE			
Parameter	Symbol	Value			Unit
		Min.	Typ.	Max.	
Frame Rate	-		60.2		Hz
DCLK Frequency	F _{DCLK}		21		MHz
Horizontal	Total line	t _H	1344		DCLK
	Active pixels	t _{Hact}	1024		DCLK
	Back porch	t _{HBP}	159		DCLK
	Pulse width	t _{HSP}	1		DCLK
	Front porch	t _{HFP}	161		DCLK
Vertical	Total time	t _V	258		H
	Active lines	t _{Vact}	100		H
	Back porch	t _{VBP}	21		H
	Pulse width	t _{VSP}	2		H
	Front porch	t _{VFP}	135		H

Note : Back porch is NOT included pulse width



(UD=L , LR=L) 反掃(右下到左上)

Timing Table HX8282A		SYNC MODE			
Parameter	Symbol	Value			Unit
		Min.	Typ.	Max.	
Frame Rate	-		60.2		Hz
DCLK Frequency	F _{DCLK}		21		MHz
Horizontal	Total line	t _H	1344		DCLK
	Active pixels	t _{Hact}	1024		DCLK
	Back porch	t _{HBP}	159		DCLK
	Pulse width	t _{HSP}	1		DCLK
	Front porch	t _{HFP}	161		DCLK
Vertical	Total time	t _V	259		H
	Active lines	t _{Vact}	100		H
	Back porch	t _{VBP}	57		H
	Pulse width	t _{VSP}	2		H
	Front porch	t _{VFP}	100		H

Note : Back porch is NOT included pulse width



9. Reliability Test

No.	SYMBOL	TEST CONDITION	REMARK
1	High Temperature Storage	80°C±2°C 96H Restore 2H at 25°C Power off	After test cosmetic and electrical defects should not happen.
2	Low Temperature Storage	-30°C±2°C 96H Restore 2H at 25°C Power off	
3	High Temperature Operation	70°C±2°C 96H Power on	
4	Low Temperature Operation	-20°C±2°C 96H Power on	
5	High Temperature & Humidity Operation	60°C±2°C 90%RH 96H Power on	
6	Temperature Cycle	-20°C←→25°C←→70°C 30min 5min 30min After 10 cycles, restore 2H at 25°C Power off	
7	Vibration Test	1. Sine wave 10~55 Hz frequency (1 min/sweep) 2. The amplitude of vibration: 1.5 mm 3. Each direction (X、Y、Z) duration for 2 Hrs	
8	Shock Test	Half-sinewave, 300m/s ² , 11ms	



10. Precautions for Using LCD Module

10.1. Handling Precautions

- (1) The display panel is made of glass. Do not subject it to a mechanical shock or impact by dropping it.
- (2) If the display panel is damaged and the liquid crystal substance leaks out, be sure not to get any in your mouth. If the substance contacts your skin or clothes, wash it off using soap and water.
- (3) Do not apply excessive force to the display surface or the adjoining areas since this may cause the color tone to vary.
- (4) The polarizer covering the display surface of the LCD module is soft and easily scratched. Handle this polarizer carefully.
- (5) If the display surface becomes contaminated, breathe on the surface and gently wipe it with a soft dry cloth. If it is heavily contaminated, moisten a cloth with one of the following solvents:
 - Isopropyl alcohol
 - Ethyl alcohol
- (6) Solvents other than those above mentioned may damage the polarizer. Especially, do not use the following:
 - Water
 - Ketone
 - Aromatic solvents
- (7) Extra care to minimize corrosion of the electrode. Water droplets, moisture condensation or a current flow in a high-humidity environment accelerates corrosion of the electrode.
- (8) Install the LCD Module by using the mounting holes. When mounting the LCD Module, make sure it is free of twisting, warping and distortion. In particular, do not forcibly pull or bend the I/O cable or the backlight cable.
- (9) Do not attempt to disassemble or process the LCD Module.
- (10) NC terminal should be open. Do not connect anything.
- (11) If the logic circuit power is off, do not apply the input signals.
- (12) To prevent destruction of the elements by static electricity, be careful to maintain an optimum work environment.
 - Be sure to ground the body when handling the LCD Module.
 - Tools required for assembling, such as soldering irons, must be properly grounded.
 - To reduce the amount of static electricity generated, do not conduct assembling and other work under dry conditions.
 - The LCD Module is coated with a film to protect the display surface. Exercise care when peeling off this protective film since static electricity may be generated.

10.2. Storage Precautions

When storing the LCD Module, avoid exposure to direct sunlight of fluorescent lamps. Keep the modules in bags (avoid high temperature/high humidity and low temperatures below 0°C). Whenever possible, the LCD Module should be stored in the same conditions in which they were shipped from our company.



10.3. Others

Liquid crystals solidify under low temperature (below the storage temperature range) leading to defective orientation or the generation of air bubbles (black or white). Air bubbles may also be generated if the module is subject to a low temperature.

If the LCD Module have been operating for a long time showing the same display patterns the display patterns may remain on the screen as ghost images and a slight contrast irregularity may also appear. A normal operating status can be recovered by suspending use for some time. It should be noted that this phenomenon does not adversely affect performance reliability.

To minimize the performance degradation of the LCD Module resulting from destruction caused by static electricity etc. exercise care to avoid holding the following sections when handling the modules.

- Exposed area of the printed circuit board.
- Terminal electrode sections.



11. Legal Information

Kingtech makes no warranty, either expressed or implied with respect to any product, and specifically disclaims all other warranties, including, without limitation, warranties for merchantability, non-infringement and fitness for any particular purpose. Information about device is the property of Kingtech and may be the subject of patents pending or granted. It is not allowed to copy or disclosed this document without prior written permission.

Kingtech endeavours to ensure that the all contained information in this document are correct but does not accept liability for any error or omission. Kingtech products are in developing p rocess and published information may be not up to date. reserves the right to update and makes changes to Specifications or written material without prior notice at any time. It is important to check the current position with Kingtech

Kingtech products are not fault tolerant nor designed, manufactured or intended for use or resale as on line control equipment in hazardous environments requiring fail – safe performance, such as in the operation of nuclear facilities, aircraft navigation or communication systems, air traffic control, direct life support machines or weapons systems in which the failure of the product could lead directly to death, personal injury or severe physical or environmental damage ('High Risk Activities'). Kingtech and its suppliers specifically disclaim any expressed or implied warranty of fitness for High Risks Activities. Using Kingtech products and devices in 'High Risk Activities' and in any other application is entirely at the buyer's risk, and the buyer agrees to defend, indemnify and hold harmless Kingtech from any and all damages, claims or expenses resulting from such use. No licenses are conveyed, implicitly or otherwise, under any Kingtech intellectual property rights.